

Reliable operation in extremely challenging conditions
Designed to comply with strict hygiene standards
Customization to user requirements



DWM HPX Checkweigher

OPERATION IN ANY CONDITIONS

DWM HPX

Weighing speed and precision ensured by electromagnetic module

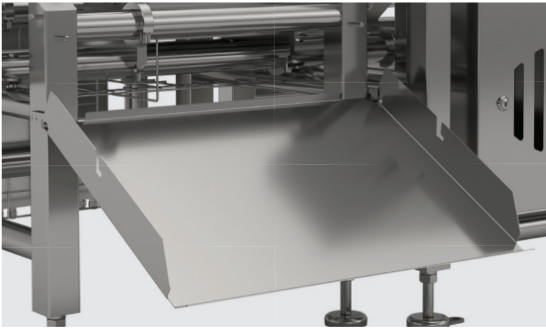

Easy-to-remove covers.

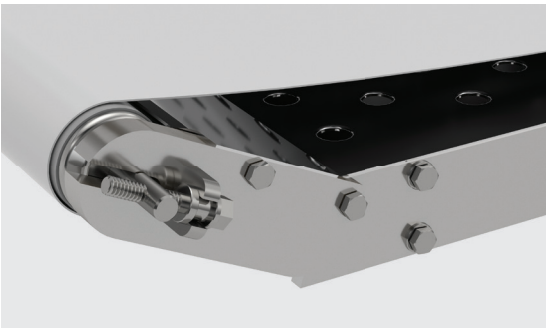

Conveyors disassembly requiring no tools.

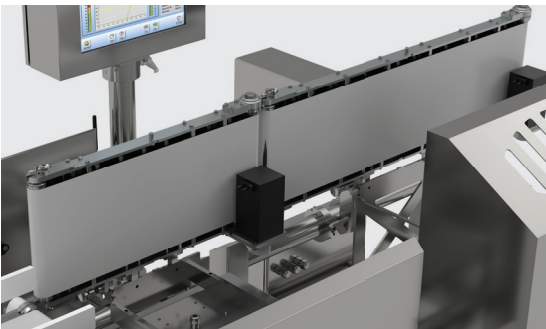

Open construction facilitating maintenance.



Indicator installed on an elevated rotary post.

Mechanical Design Compliant with HACCP

DWM HPX checkweigher is designed in accordance with 'hygienic design' requirements. Adopted solutions minimize potential spots where contamination can accumulate, and facilitate maintenance. Among these solutions there are: round-profile construction, no places accumulating contamination, fast disassembly of conveyors and belts requiring no tools, less flat horizontal surfaces on which contamination may accumulate, stainless steel mechanical design (AISI 304 or 316). Specially-designed gaskets, seal wires and shields guarantee IP69K ingress protection.

Intended Use

This series of checkweighers is intended for food industry, it is especially useful on fish and meat processing production halls. The applied solutions and materials are compliant with strict hygiene standards required for food production. Reinforced, hermetic construction allows to clean the device with pressure washer.

Measurement Speed and Precision

Mass measurement using DWM HPX checkweigher is carried out with up to 0.5g readability, on an electromagnetic weighing module housed in a hermetic housing of IP69K ingress protection.

Clear Information Layout

The 12" display with a touch panel enables easy access to the main functions and clear presentation of the most important information during operation, e.g. current mass value, current statistics, production line throughput and function buttons.

Databases

The DWM checkweigher features an SQL database. The database stores lists of products, operators and measurement reports.

Connectivity with Central Database System

E2R software enables synchronization of local databases of particular weighing instruments with a central database. With this, it is possible to preview and manage data from the weighing system administrator's computer.

Compliance with Global Standards

DWM HPX checkweighers have type approval certification compliant with the MID directive, and have passed tests carried out in accordance with OIML R51. The checkweigher software enables creation of different permission levels for operators, and registers operations carried out on the scale along with possible operator errors.



DWM HPX

Maximum capacity [Max]	1500 – 7500 g
Readability [d]	0.5 – 5 g
Conveyor speed	1.6 m/s
Design	Stainless steel AISI304 or AISI316
OIML class	XIII(1), Y(a)
Ingress protection	IP69K
Communication interfaces	USB, Ethernet, RS 232, IN, OUT