

MWSH weighing modules

Series of professional electromagnetic modules of high resolution guarantees highly precise and fast measurement.



Easy access to the most functional interfaces



Ease of adaptation to the required storage space

MWSH

Features

Vast Max Capacity Range

Magnetolectric weighing modules MWSH are intended for mass measurement ranging from 35kg to 60kg. Minimum readability of 0.01g guarantees amazing accuracy for your measurement.

Ease of Installation

Compact dimensions and ergonomic installation handles enable easy and fast integration of the module into a production line. Innovative internal design allows control of automation systems installed directly on a weighing pan. Applied solution, i.e. system transferring electric signal to the weighing platform, eliminates necessity to feed external cables disturbing the weighing process.

Internal Auto-Adjustment

A built-in system of automatic internal adjustment guarantees correct weighing results even for the highest readability. Adjustment is carried out within specified time intervals or with reference to a schedule, it can also be triggered by temperature change. Option of adjustment time setup enables adapting adjustment processes to production line schedule.

Protection Against Challenging Conditions

Hermetic versions of modules feature stainless steel housing with IP 65. This allows operation even in the most challenging conditions. Mechanical design lacks sharp edges and gaps which ensures adherence to HACCP, GMP and FDA standards for safety and quality of operation.

Fast and Precise Measurement

High measurement accuracy with $sd=1d^*$ guarantees both readout of real weighing results and repeatability of indications. Cutting-edge design solutions provide fast measurement which is an asset allowing to install the module on automated production lines. Intended for fast and dynamic measuring processes the weighing module's converter throughput is 3200 meas./s **.

Cooperation with terminals

Connecting the module to a multifunctional weighing terminal expands communication interfaces range and increases usage in industrial applications.

Technical Specifications

	MWSH 6000
Maximum capacity [Max]	60 kg
Minimum capacity	600 g
Input load (preload range)	0.5 g
Readability [d]	0.01 g
Verification unit [e]	—
Tare range	−60 kg
Repeatability*	0.015 g
Linearity	±0.03 g
Sensitivity temperature drift**	$2 \times 10^{-6} / ^\circ\text{C} \times \text{Rt}$
Stabilization time	1.5 s
Adjustment	internal
Verification	—
OIML Class	—
Construction material	construction - aluminium, housing - AISI306
Weighing pan material	aluminium
Display	—
Protection class	IP 65
RS 232	1
RS 485	1
Ethernet	1
IN/OUT	2 × IN, 2 × OUT
Transmission protocols	RADWAG, ASCII code, MODBUS
PROFIBUS module***	1
Power supply	12 ÷ 24 V DC
Power consumption	5 W
Operating temperature	+10 ÷ +40 °C
Atmospheric humidity****	15 ÷ 80%
Transport and storage temperature	−20 ÷ +50 °C
Weighing pan dimensions	100 × 100 mm
Weighing device dimensions	341 × 236 × 164 mm
Net weight	6 kg
Gross weight	8.5 kg
Packaging dimensions	580 × 335 × 280 mm

- Rt net weight
 * repeatability is expressed as a standard deviation from 10 weighing cycles
 ** parameter determined in the following temperature range: +15 ÷ +35 °C
 *** interface installed interchangeably with Ethernet, IN/OUT, RS 485
 **** non-condensing conditions

Dimensions

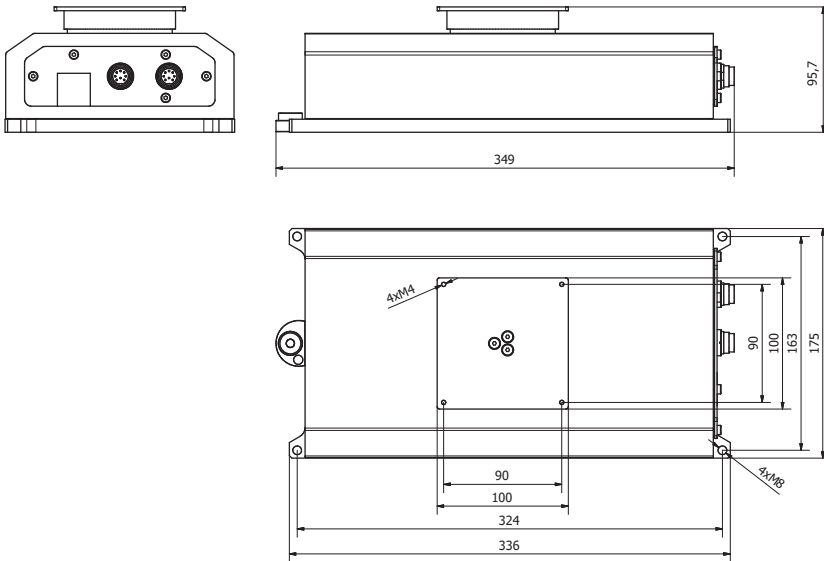

MWSH

Accessories

Cables, Converters

- PT0347 – RS 232 cable (platform – terminal PUE HY10, PUE 5)
- PT0348 – RS 232 cable (platform – computer)
- PT0302 – Ethernet cable with straight plug (platform - terminal PUE HY10, PUE 5)
- PT0303 – Ethernet cable with angle plug (platform - terminal PUE HY10, PUE 5)
- PT0256 – IN/OUT cable
- P0198 – Ethernet cable (M12 4P)

Compatible Weighing Werminals

- PUE HY10

Electrical Accessories

- power supply SYS-1544-2415-T3-HR

Dedicated Software

MWMH-Manager

- option of adjustment of HRP platforms and MWSH, MWLH and MWMH modules
- option of readout of mass from HRP platforms and modules using the computer
- option of taring and zeroing HRP platforms and modules using the computer
- option of setting weighing filters for HRP platforms and modules

RADWAG Development Studio

- presentation of functions (and subfunctions) of communication protocol (Common Communication Protocol)
- possibility of connection with weighing equipment on which each function is carried out
- library with mass control, contained within the development environment
- complete documentation of the communication protocol
- set of user manuals for different solutions addressed for programmers employed in companies using RADWAG-manufactured weighing equipment

LabView Driver

- operation of RADWAG balances in LabView environment

RADWAG Connect

- establishing communication with all balances, scales and weighing modules using Common Communication Protocol
- communication via local network
- support of basic functions
- auto searching for devices
- connecting with few devices simultaneously, swapping between them
- clear list of connected platforms
- record of measurements in the program
- export of carried out measurements to CSV file
- work performed using freely selected device with Windows 10 operating system