

# HY10.H Multifunctional Scale

Wide range of functions and unlimited possibilities of application in processes of mass measurement in moist environment and at direct contact with water

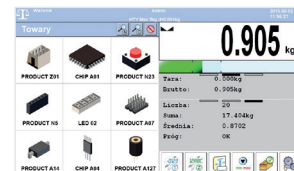

Products database with images assigned to each product

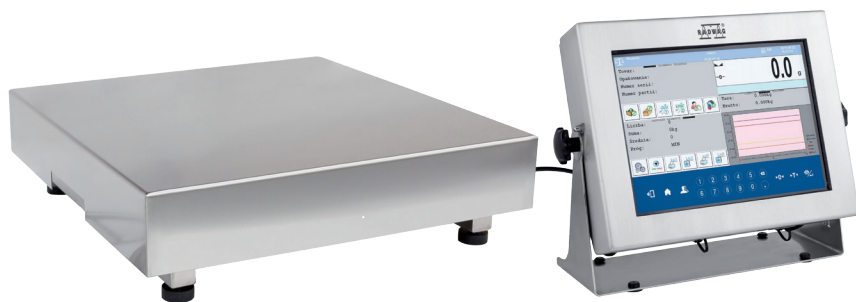

PUE HY10 indicator with 10.1" colour touch panel

HY10.H.K

## Functions

- |                |                       |                             |                            |                   |
|----------------|-----------------------|-----------------------------|----------------------------|-------------------|
| Parts counting | Percent weighing      | Statistical quality control | Peak hold                  | Smart select      |
| Dosing         | Statistics            | Density determination       | Totalizing                 | Alibi memory      |
| Checkweighing  | Animal weighing       | Labelling                   | Pre-packaged goods control | Replaceable units |
| Formulations   | Differential weighing | Transactions                | GLP procedures             | Multilingual menu |

## Features

### Precise Weighing Results in Industrial Conditions

Advanced HY10.H multifunctional scale enables fast and precise mass measurements in challenging industrial conditions.

### Robustness and Resistance to Ambient Conditions

Robust platform made of stainless steel and high ingress protection allow to operate in moist environment and at direct contact with water.

### Vast Range of Applications

Numerous functions and applications of HY10 scale enable carrying out parts counting, formulations, dosing and labelling.

### Cooperation with PUE HY10 Indicator

The scale can be operated via advanced PUE HY10 indicator controlled by Windows system. Hermetic housing is made of stainless steel.

### Uncomplicated Operation and Clear Presentation of Indications

10.1" large colour touch screen ensures excellent readability and comfortable operation. Clear menu and intuitive information arrangement on the display guarantees uncomplicated and comfortable operation.

### Remote Configuration

Parameters Editor software enables remote indicator operation from anywhere in the world.

### Uncomplicated Databases Archiving

An extensive database enables archiving work results and periodic reports, data exchange between indicators and information import and export. Images database allows to assign a graphic to each product.

## Technical Specifications

	<b>HY10.1,5.H1.K</b>	<b>HY10.3.H1.K*</b>	<b>HY10.6.H1.K*</b>
<b>Maximum capacity [Max]</b>	1.5 kg	3 kg	6 kg
<b>Minimum capacity</b>	10 g	20 g	40 g
<b>Readability [d]</b>	0.5 g	1 g	2 g
<b>Max readability for non-verified scale</b>	0.2 g	0.2 g	0.2 g
<b>Verification unit [e]</b>	0.5 g	1 g	2 g
<b>Tare range</b>	-1,5 kg	-3 kg	-6 kg
<b>Verification</b>	Yes	Yes	Yes
<b>OIML class</b>	III	III	III
<b>Optional quantity of weighing platforms**</b>	Maximum 6 (2 × internal weighing module + 4 × external weighing module)	Maximum 6 (2 × internal weighing module + 4 × external weighing module)	Maximum 6 (2 × internal weighing module + 4 × external weighing module)
<b>Platform material</b>	AISI304 stainless steel	AISI304 stainless steel	AISI304 stainless steel
<b>Weighing pan material</b>	AISI304 stainless steel	AISI304 stainless steel	AISI304 stainless steel
<b>Indicator fastening</b>	cable (K)	cable (K)	cable (K)
<b>Display</b>	10.1" touch panel	10.1" touch panel	10.1" touch panel
<b>Keyboard</b>	on-screen	on-screen	on-screen
<b>Indicator type</b>	PUE HY10	PUE HY10	PUE HY10
<b>Ingress protection - platform</b>	IP 68	IP 68	IP 68
<b>Ingress protection - indicator</b>	IP 68/69	IP 68/69	IP 68/69
<b>USB</b>	1 × type A, 1 × MR 4 PIN	1 × type A, 1 × MR 4 PIN	1 × type A, 1 × MR 4 PIN
<b>RS 485</b>	1	1	1
<b>RS 232</b>	1	1	1
<b>Ethernet</b>	10 / 100 Mbit	10 / 100 Mbit	10 / 100 Mbit
<b>IN/OUT</b>	4 × IN, 4 × OUT for (IN – 5-24 VDC, OUT – max 30 VDC, 0,5 ADC)	4 × IN, 4 × OUT for (IN – 5-24 VDC, OUT – max 30 VDC, 0,5 ADC)	4 × IN, 4 × OUT for (IN – 5-24 VDC, OUT – max 30 VDC, 0,5 ADC)
<b>PROFIBUS module**</b>	DP SLAVE	DP SLAVE	DP SLAVE
<b>PROFINET Module**</b>	1 × type RJ45	1 × type RJ45	1 × type RJ45
<b>AN module**</b>	4-20mA, 0-20mA current loop; 0-10V voltage loop	4-20mA, 0-20mA current loop; 0-10V voltage loop	4-20mA, 0-20mA current loop; 0-10V voltage loop
<b>WE12 module**</b>	12IN / 12OUT - cable gland for (IN – 5-24 VDC, OUT – max 30 VDC, 0,5 ADC)	12IN / 12OUT - cable gland for (IN – 5-24 VDC, OUT – max 30 VDC, 0,5 ADC)	12IN / 12OUT - cable gland for (IN – 5-24 VDC, OUT – max 30 VDC, 0,5 ADC)
<b>Wireless Module**</b>	YES (external antenna) 802.11 b/g/n	YES (external antenna) 802.11 b/g/n	YES (external antenna) 802.11 b/g/n
<b>Power supply</b>	100 ÷ 240V AC 50÷60Hz	100 ÷ 240V AC 50÷60Hz	100 ÷ 240V AC 50÷60Hz
<b>Power consumption</b>	21 W	21 W	21 W
<b>Operating temperature</b>	+10 ÷ +40 °C	+10 ÷ +40 °C	+10 ÷ +40 °C
<b>Relative humidity ***</b>	40 ÷ 80%	40 ÷ 80%	40 ÷ 80%
<b>Transport and storage temperature</b>	-10 ÷ +50 °C	-10 ÷ +50 °C	-10 ÷ +50 °C
<b>Weighing pan dimensions</b>	200 × 150 mm	200 × 150 mm	200 × 150 mm
<b>Indicator dimensions</b>	360 × 275 × 120 mm	360 × 275 × 120 mm	360 × 275 × 120 mm
<b>Net weight</b>	8.8 kg	8.8 kg	8.8 kg
<b>Gross weight</b>	11.1 kg	11.1 kg	11.1 kg
<b>Platform packaging dimensions</b>	290 × 270 × 240 mm	290 × 270 × 240 mm	290 × 270 × 240 mm
<b>Indicator packaging dimensions</b>	420 × 350 × 230 mm	420 × 350 × 230 mm	420 × 350 × 230 mm

\* option: dual range weighing instrument

\*\* optional scale design

\*\*\* non-condensing conditions

## Technical Specifications

	<b>HY10.15.H1.K</b>	<b>HY10.3.H2.K</b>	<b>HY10.6.H2.K*</b>
<b>Maximum capacity [Max]</b>	15 kg	3 kg	6 kg
<b>Minimum capacity</b>	100 g	20 g	40 g
<b>Readability [d]</b>	5 g	1 g	2 g
<b>Max readability for non-verified scale</b>	0.5 g	0,2 g	0,2 g
<b>Verification unit [e]</b>	5 g	1 g	2 g
<b>Tare range</b>	-15 kg	-3 kg	-6 kg
<b>Verification</b>	Yes	Yes	Yes
<b>OIML class</b>	III	III	III
<b>Optional quantity of weighing platforms**</b>	Maximum 6 (2 × internal weighing module + 4 × external weighing module)	Maximum 6 (2 × internal weighing module + 4 × external weighing module)	Maximum 6 (2 × internal weighing module + 4 × external weighing module)
<b>Platform material</b>	AISI304 stainless steel	AISI304 stainless steel	AISI304 stainless steel
<b>Weighing pan material</b>	AISI304 stainless steel	AISI304 stainless steel	AISI304 stainless steel
<b>Indicator fastening</b>	cable (K)	cable (K)	cable (K)
<b>Display</b>	10.1" touch panel	10.1" touch panel	10.1" touch panel
<b>Keyboard</b>	on-screen	on-screen	on-screen
<b>Indicator type</b>	PUE HY10	PUE HY10	PUE HY10
<b>Ingress protection - platform</b>	IP 68	IP 68	IP 68
<b>Ingress protection - indicator</b>	IP 68/69	IP 68/69	IP 68/69
<b>USB</b>	1 × type A, 1 × MR 4 PIN	1 × type A, 1 × MR 4 PIN	1 × type A, 1 × MR 4 PIN
<b>RS 485</b>	1	1	1
<b>RS 232</b>	1	1	1
<b>Ethernet</b>	10 / 100 Mbit	10 / 100 Mbit	10 / 100 Mbit
<b>IN/OUT</b>	4 × IN, 4 × OUT for (IN – 5-24 VDC, OUT – max 30 VDC, 0,5 ADC)	4 × IN, 4 × OUT for (IN – 5-24 VDC, OUT – max 30 VDC, 0,5 ADC)	4 × IN, 4 × OUT for (IN – 5-24 VDC, OUT – max 30 VDC, 0,5 ADC)
<b>PROFIBUS module**</b>	DP SLAVE	DP SLAVE	DP SLAVE
<b>PROFINET Module**</b>	1 × type RJ45	1 × type RJ45	1 × type RJ45
<b>AN module**</b>	4-20mA, 0-20mA current loop; 0-10V voltage loop	4-20mA, 0-20mA current loop; 0-10V voltage loop	4-20mA, 0-20mA current loop; 0-10V voltage loop
<b>WE12 module**</b>	12IN / 12OUT - cable gland for (IN – 5-24 VDC, OUT – max 30 VDC, 0,5 ADC)	12IN / 12OUT - cable gland for (IN – 5-24 VDC, OUT – max 30 VDC, 0,5 ADC)	12IN / 12OUT - cable gland for (IN – 5-24 VDC, OUT – max 30 VDC, 0,5 ADC)
<b>Wireless Module**</b>	YES (external antenna) 802.11 b/g/n	YES (external antenna) 802.11 b/g/n	YES (external antenna) 802.11 b/g/n
<b>Power supply</b>	100 ÷ 240V AC 50÷60Hz	100 ÷ 240V AC 50÷60Hz	100 ÷ 240V AC 50÷60Hz
<b>Power consumption</b>	21 W	21 W	21 W
<b>Operating temperature</b>	+10 ÷ +40 °C	+10 ÷ +40 °C	+10 ÷ +40 °C
<b>Relative humidity ***</b>	40 ÷ 80%	40 ÷ 80%	40 ÷ 80%
<b>Transport and storage temperature</b>	-10 ÷ +50 °C	-10 ÷ +50 °C	-10 ÷ +50 °C
<b>Weighing pan dimensions</b>	200 × 150 mm	250 × 300 mm	250 × 300 mm
<b>Indicator dimensions</b>	360 × 275 × 120 mm	360 × 275 × 120 mm	360 × 275 × 120 mm
<b>Net weight</b>	8.8 kg	11.2 kg	11.2 kg
<b>Gross weight</b>	11.1 kg	14.2 kg	14.2 kg
<b>Platform packaging dimensions</b>	290 × 270 × 240 mm	580 × 320 × 360 mm	580 × 320 × 360 mm
<b>Indicator packaging dimensions</b>	420 × 350 × 230 mm	420 × 350 × 230 mm	420 × 350 × 230 mm

\* option: dual range weighing instrument

\*\* optional scale design

\*\*\* non-condensing conditions

## Technical Specifications

	HY10.15.H2.K*	HY10.30.H2.K*	HY10.6.H3.K
Maximum capacity [Max]	15 kg	30 kg	6 kg
Minimum capacity	100 g	200 g	40 g
Readability [d]	5 g	10 g	2 g
Max readability for non-verified scale	1 g	1 g	0.5 g
Verification unit [e]	5 g	10 g	2 g
Tare range	-15 kg	-20 kg	-6 kg
Verification	Yes	Yes	Yes
OIML class	III	III	III
Optional quantity of weighing platforms**	Maximum 6 (2 × internal weighing module + 4 × external weighing module)	Maximum 6 (2 × internal weighing module + 4 × external weighing module)	Maximum 6 (2 × internal weighing module + 4 × external weighing module)
Platform material	AISI304 stainless steel	AISI304 stainless steel	AISI304 stainless steel
Weighing pan material	AISI304 stainless steel	AISI304 stainless steel	AISI304 stainless steel
Indicator fastening	cable (K)	cable (K)	cable (K)
Display	10.1" touch panel	10.1" touch panel	10.1" touch panel
Keyboard	on-screen	on-screen	on-screen
Indicator type	PUE HY10	PUE HY10	PUE HY10
Ingress protection - platform	IP 68	IP 68	IP 68
Ingress protection - indicator	IP 68/69	IP 68/69	IP 68/69
USB	1 × type A, 1 × MR 4 PIN	1 × type A, 1 × MR 4 PIN	1 × type A, 1 × MR 4 PIN
RS 485	1	1	1
RS 232	1	1	1
Ethernet	10 / 100 Mbit	10 / 100 Mbit	10 / 100 Mbit
IN/OUT	4 × IN, 4 × OUT for (IN – 5-24 VDC, OUT – max 30 VDC, 0,5 ADC)	4 × IN, 4 × OUT for (IN – 5-24 VDC, OUT – max 30 VDC, 0,5 ADC)	4 × IN, 4 × OUT for (IN – 5-24 VDC, OUT – max 30 VDC, 0,5 ADC)
PROFIBUS module**	DP SLAVE	DP SLAVE	DP SLAVE
PROFINET Module**	1 × type RJ45	1 × type RJ45	1 × type RJ45
AN module**	4-20mA, 0-20mA current loop; 0-10V voltage loop	4-20mA, 0-20mA current loop; 0-10V voltage loop	4-20mA, 0-20mA current loop; 0-10V voltage loop
WE12 module**	12IN / 12OUT - cable gland for (IN – 5-24 VDC, OUT – max 30 VDC, 0,5 ADC)	12IN / 12OUT - cable gland for (IN – 5-24 VDC, OUT – max 30 VDC, 0,5 ADC)	12IN / 12OUT - cable gland for (IN – 5-24 VDC, OUT – max 30 VDC, 0,5 ADC)
Wireless Module**	YES (external antenna) 802.11 b/g/n	YES (external antenna) 802.11 b/g/n	YES (external antenna) 802.11 b/g/n
Power supply	100 ÷ 240V AC 50÷60Hz	100 ÷ 240V AC 50÷60Hz	100 ÷ 240V AC 50÷60Hz
Power consumption	21 W	21 W	21 W
Operating temperature	+10 ÷ +40 °C	+10 ÷ +40 °C	+10 ÷ +40 °C
Relative humidity ***	40 ÷ 80%	40 ÷ 80%	40 ÷ 80%
Transport and storage temperature	-10 ÷ +50 °C	-10 ÷ +50 °C	-10 ÷ +50 °C
Weighing pan dimensions	250 × 300 mm	250 × 300 mm	410 × 410 mm
Indicator dimensions	360 × 275 × 120 mm	360 × 275 × 120 mm	360 × 275 × 120 mm
Net weight	11.2 kg	11.2 kg	13,2 kg
Gross weight	14.2 kg	14.2 kg	17,4 kg
Platform packaging dimensions	580 × 320 × 360 mm	580 × 320 × 360 mm	670 × 510 × 330 mm
Indicator packaging dimensions	420 × 350 × 230 mm	420 × 350 × 230 mm	420 × 350 × 230 mm

\* option: dual range weighing instrument

\*\* optional scale design

\*\*\* non-condensing conditions

## Technical Specifications

	HY10.15.H3.K*	HY10.30.H3.K*	HY10.60.H3.K*
<b>Maximum capacity [Max]</b>	15 kg	30 kg	60 kg
<b>Minimum capacity</b>	100 g	200 g	400 g
<b>Readability [d]</b>	5 g	10 g	20 g
<b>Max readability for non-verified scale</b>	1 g	1 g	2 g
<b>Verification unit [e]</b>	5 g	10 g	20 g
<b>Tare range</b>	-15 kg	-30 kg	-60 kg
<b>Verification</b>	Yes	Yes	Yes
<b>OIML class</b>	III	III	III
<b>Optional quantity of weighing platforms**</b>	Maximum 6 (2 × internal weighing module + 4 × external weighing module)	Maximum 6 (2 × internal weighing module + 4 × external weighing module)	Maximum 6 (2 × internal weighing module + 4 × external weighing module)
<b>Platform material</b>	AISI304 stainless steel	AISI304 stainless steel	AISI304 stainless steel
<b>Weighing pan material</b>	AISI304 stainless steel	AISI304 stainless steel	AISI304 stainless steel
<b>Indicator fastening</b>	cable (K)	cable (K)	cable (K)
<b>Display</b>	10.1" touch panel	10.1" touch panel	10.1" touch panel
<b>Keyboard</b>	on-screen	on-screen	on-screen
<b>Indicator type</b>	PUE HY10	PUE HY10	PUE HY10
<b>Ingress protection - platform</b>	IP 68	IP 68	IP 68
<b>Ingress protection - indicator</b>	IP 68/69	IP 68/69	IP 68/69
<b>USB</b>	1 × type A, 1 × MR 4 PIN	1 × type A, 1 × MR 4 PIN	1 × type A, 1 × MR 4 PIN
<b>RS 485</b>	1	1	1
<b>RS 232</b>	1	1	1
<b>Ethernet</b>	10 / 100 Mbit	10 / 100 Mbit	10 / 100 Mbit
<b>IN/OUT</b>	4 × IN, 4 × OUT for (IN – 5-24 VDC, OUT – max 30 VDC, 0,5 ADC)	4 × IN, 4 × OUT for (IN – 5-24 VDC, OUT – max 30 VDC, 0,5 ADC)	4 × IN, 4 × OUT for (IN – 5-24 VDC, OUT – max 30 VDC, 0,5 ADC)
<b>PROFIBUS module**</b>	DP SLAVE	DP SLAVE	DP SLAVE
<b>PROFINET Module**</b>	1 × type RJ45	1 × type RJ45	1 × type RJ45
<b>AN module**</b>	4-20mA, 0-20mA current loop; 0-10V voltage loop	4-20mA, 0-20mA current loop; 0-10V voltage loop	4-20mA, 0-20mA current loop; 0-10V voltage loop
<b>WE12 module**</b>	12IN / 12OUT - cable gland for (IN – 5-24 VDC, OUT – max 30 VDC, 0,5 ADC)	12IN / 12OUT - cable gland for (IN – 5-24 VDC, OUT – max 30 VDC, 0,5 ADC)	12IN / 12OUT - cable gland for (IN – 5-24 VDC, OUT – max 30 VDC, 0,5 ADC)
<b>Wireless Module**</b>	YES (external antenna) 802.11 b/g/n	YES (external antenna) 802.11 b/g/n	YES (external antenna) 802.11 b/g/n
<b>Power supply</b>	100 ÷ 240V AC 50÷60Hz	100 ÷ 240V AC 50÷60Hz	100 ÷ 240V AC 50÷60Hz
<b>Power consumption</b>	21 W	21 W	21 W
<b>Operating temperature</b>	+10 ÷ +40 °C	+10 ÷ +40 °C	+10 ÷ +40 °C
<b>Relative humidity ***</b>	40 ÷ 80%	40 ÷ 80%	40 ÷ 80%
<b>Transport and storage temperature</b>	-10 ÷ +50 °C	-10 ÷ +50 °C	-10 ÷ +50 °C
<b>Weighing pan dimensions</b>	410 × 410 mm	410 × 410 mm	410 × 410 mm
<b>Indicator dimensions</b>	360 × 275 × 120 mm	360 × 275 × 120 mm	360 × 275 × 120 mm
<b>Net weight</b>	13,2 kg	13,2 kg	13,2 kg
<b>Gross weight</b>	17,4 kg	17,4 kg	17,4 kg
<b>Platform packaging dimensions</b>	670 × 510 × 330 mm	670 × 510 × 330 mm	670 × 510 × 330 mm
<b>Indicator packaging dimensions</b>	420 × 350 × 230 mm	420 × 350 × 230 mm	420 × 350 × 230 mm

\* option: dual range weighing instrument

\*\* optional scale design

\*\*\* non-condensing conditions

## Technical Specifications

	<b>HY10.150.H3.K*</b>	<b>HY10.15.H4.K*</b>	<b>HY10.30.H4.K*</b>
<b>Maximum capacity [Max]</b>	150 kg	15 kg	30 kg
<b>Minimum capacity</b>	1000 g	100 g	200 g
<b>Readability [d]</b>	50 g	5 g	10 g
<b>Max readability for non-verified scale</b>	5 g	0,5 g	1 g
<b>Verification unit [e]</b>	50 g	5 g	10 g
<b>Tare range</b>	-150 kg	-15 kg	-30 kg
<b>Verification</b>	Yes	Yes	Yes
<b>OIML class</b>	III	III	III
<b>Optional quantity of weighing platforms**</b>	Maximum 6 (2 × internal weighing module + 4 × external weighing module)	Maximum 6 (2 × internal weighing module + 4 × external weighing module)	Maximum 6 (2 × internal weighing module + 4 × external weighing module)
<b>Platform material</b>	AISI304 stainless steel	AISI304 stainless steel	AISI304 stainless steel
<b>Weighing pan material</b>	AISI304 stainless steel	AISI304 stainless steel	AISI304 stainless steel
<b>Indicator fastening</b>	cable (K)	cable (K)	cable (K)
<b>Display</b>	10.1" touch panel	10.1" touch panel	10.1" touch panel
<b>Keyboard</b>	on-screen	on-screen	on-screen
<b>Indicator type</b>	PUE HY10	PUE HY10	PUE HY10
<b>Ingress protection - platform</b>	IP 68	IP 68	IP 68
<b>Ingress protection - indicator</b>	IP 68/69	IP 68/69	IP 68/69
<b>USB</b>	1 × type A, 1 × MR 4 PIN	1 × type A, 1 × MR 4 PIN	1 × type A, 1 × MR 4 PIN
<b>RS 485</b>	1	1	1
<b>RS 232</b>	1	1	1
<b>Ethernet</b>	10 / 100 Mbit	10 / 100 Mbit	10 / 100 Mbit
<b>IN/OUT</b>	4 × IN, 4 × OUT for (IN – 5-24 VDC, OUT – max 30 VDC, 0,5 ADC)	4 × IN, 4 × OUT for (IN – 5-24 VDC, OUT – max 30 VDC, 0,5 ADC)	4 × IN, 4 × OUT for (IN – 5-24 VDC, OUT – max 30 VDC, 0,5 ADC)
<b>PROFIBUS module**</b>	DP SLAVE	DP SLAVE	DP SLAVE
<b>PROFINET Module**</b>	1 × type RJ45	1 × type RJ45	1 × type RJ45
<b>AN module**</b>	4-20mA, 0-20mA current loop; 0-10V voltage loop	4-20mA, 0-20mA current loop; 0-10V voltage loop	4-20mA, 0-20mA current loop; 0-10V voltage loop
<b>WE12 module**</b>	12IN / 12OUT - cable gland for (IN – 5-24 VDC, OUT – max 30 VDC, 0,5 ADC)	12IN / 12OUT - cable gland for (IN – 5-24 VDC, OUT – max 30 VDC, 0,5 ADC)	12IN / 12OUT - cable gland for (IN – 5-24 VDC, OUT – max 30 VDC, 0,5 ADC)
<b>Wireless Module**</b>	YES (external antenna) 802.11 b/g/n	YES (external antenna) 802.11 b/g/n	YES (external antenna) 802.11 b/g/n
<b>Power supply</b>	100 ÷ 240V AC 50÷60Hz	100 ÷ 240V AC 50÷60Hz	100 ÷ 240V AC 50÷60Hz
<b>Power consumption</b>	21 W	21 W	21 W
<b>Operating temperature</b>	+10 ÷ +40 °C	+10 ÷ +40 °C	+10 ÷ +40 °C
<b>Relative humidity ***</b>	40 ÷ 80%	40 ÷ 80%	40 ÷ 80%
<b>Transport and storage temperature</b>	-10 ÷ +50 °C	-10 ÷ +50 °C	-10 ÷ +50 °C
<b>Weighing pan dimensions</b>	410 × 410 mm	500 × 500 mm	500 × 500 mm
<b>Indicator dimensions</b>	360 × 275 × 120 mm	360 × 275 × 120 mm	360 × 275 × 120 mm
<b>Net weight</b>	13,2 kg	21.3 kg	21.3 kg
<b>Gross weight</b>	17,4 kg	26.8 kg	26.8 kg
<b>Platform packaging dimensions</b>	670 × 510 × 330 mm	840 × 600 × 400 mm	840 × 600 × 400 mm
<b>Indicator packaging dimensions</b>	420 × 350 × 230 mm	420 × 350 × 230 mm	420 × 350 × 230 mm

\* option: dual range weighing instrument

\*\* optional scale design

\*\*\* non-condensing conditions

## Technical Specifications

	<b>HY10.60.H4.K*</b>	<b>HY10.150.H4.K*</b>	<b>HY10.15.H3/5.K</b>
<b>Maximum capacity [Max]</b>	60 kg	150 kg	15 kg
<b>Minimum capacity</b>	400 g	1000 g	100 g
<b>Readability [d]</b>	20 g	50 g	5 g
<b>Max readability for non-verified scale</b>	2 g	5 g	0.5 g
<b>Verification unit [e]</b>	20 g	50 g	5 g
<b>Tare range</b>	-60 kg	-150 kg	-15 kg
<b>Verification</b>	Yes	Yes	Yes
<b>OIML class</b>	III	III	III
<b>Optional quantity of weighing platforms**</b>	Maximum 6 (2 × internal weighing module + 4 × external weighing module)	Maximum 6 (2 × internal weighing module + 4 × external weighing module)	Maximum 6 (2 × internal weighing module + 4 × external weighing module)
<b>Platform material</b>	AISI304 stainless steel	AISI304 stainless steel	AISI304 stainless steel
<b>Weighing pan material</b>	AISI304 stainless steel	AISI304 stainless steel	AISI304 stainless steel
<b>Indicator fastening</b>	cable (K)	cable (K)	cable (K)
<b>Display</b>	10.1" touch panel	10.1" touch panel	10.1" touch panel
<b>Keyboard</b>	on-screen	on-screen	on-screen
<b>Indicator type</b>	PUE HY10	PUE HY10	PUE HY10
<b>Ingress protection - platform</b>	IP 68	IP 68	IP 68
<b>Ingress protection - indicator</b>	IP 68/69	IP 68/69	IP 68/69
<b>USB</b>	1 × type A, 1 × MR 4 PIN	1 × type A, 1 × MR 4 PIN	1 × type A, 1 × MR 4 PIN
<b>RS 485</b>	1	1	1
<b>RS 232</b>	1	1	1
<b>Ethernet</b>	10 / 100 Mbit	10 / 100 Mbit	10 / 100 Mbit
<b>IN/OUT</b>	4 × IN, 4 × OUT for (IN – 5-24 VDC, OUT – max 30 VDC, 0,5 ADC)	4 × IN, 4 × OUT for (IN – 5-24 VDC, OUT – max 30 VDC, 0,5 ADC)	4 × IN, 4 × OUT for (IN – 5-24 VDC, OUT – max 30 VDC, 0,5 ADC)
<b>PROFIBUS module**</b>	DP SLAVE	DP SLAVE	DP SLAVE
<b>PROFINET Module**</b>	1 × type RJ45	1 × type RJ45	1 × type RJ45
<b>AN module**</b>	4-20mA, 0-20mA current loop; 0-10V voltage loop	4-20mA, 0-20mA current loop; 0-10V voltage loop	4-20mA, 0-20mA current loop; 0-10V voltage loop
<b>WE12 module**</b>	12IN / 12OUT - cable gland for (IN – 5-24 VDC, OUT – max 30 VDC, 0,5 ADC)	12IN / 12OUT - cable gland for (IN – 5-24 VDC, OUT – max 30 VDC, 0,5 ADC)	12IN / 12OUT - cable gland for (IN – 5-24 VDC, OUT – max 30 VDC, 0,5 ADC)
<b>Wireless Module**</b>	YES (external antenna) 802.11 b/g/n	YES (external antenna) 802.11 b/g/n	YES (external antenna) 802.11 b/g/n
<b>Power supply</b>	100 ÷ 240V AC 50÷60Hz	100 ÷ 240V AC 50÷60Hz	100 ÷ 240V AC 50÷60Hz
<b>Power consumption</b>	21 W	21 W	21 W
<b>Operating temperature</b>	+10 ÷ +40 °C	+10 ÷ +40 °C	+10 ÷ +40 °C
<b>Relative humidity ***</b>	40 ÷ 80%	40 ÷ 80%	40 ÷ 80%
<b>Transport and storage temperature</b>	-10 ÷ +50 °C	-10 ÷ +50 °C	-10 ÷ +50 °C
<b>Weighing pan dimensions</b>	500 × 500 mm	500 × 500 mm	400 × 600 mm
<b>Indicator dimensions</b>	360 × 275 × 120 mm	360 × 275 × 120 mm	360 × 275 × 120 mm
<b>Net weight</b>	21.3 kg	21.3 kg	23 kg
<b>Gross weight</b>	26.8 kg	26.8 kg	27.8 kg
<b>Platform packaging dimensions</b>	840 × 600 × 400 mm	840 × 600 × 400 mm	670 × 510 × 330 mm
<b>Indicator packaging dimensions</b>	420 × 350 × 230 mm	420 × 350 × 230 mm	420 × 350 × 230 mm

\* option: dual range weighing instrument

\*\* optional scale design

\*\*\* non-condensing conditions

## Technical Specifications

	HY10.30.H3/5.K*	HY10.60.H3/5.K	HY10.150.H3/5.K
<b>Maximum capacity [Max]</b>	30 kg	60 kg	150 kg
<b>Minimum capacity</b>	200 g	400 g	1000 g
<b>Readability [d]</b>	10 g	20 g	50 g
<b>Max readability for non-verified scale</b>	1 g	2 g	5 g
<b>Verification unit [e]</b>	10 g	20 g	50 g
<b>Tare range</b>	-30 kg	-60 kg	-150 kg
<b>Verification</b>	Yes	Yes	Yes
<b>OIML class</b>	III	III	III
<b>Optional quantity of weighing platforms**</b>	Maximum 6 (2 × internal weighing module + 4 × external weighing module)	Maximum 6 (2 × internal weighing module + 4 × external weighing module)	Maximum 6 (2 × internal weighing module + 4 × external weighing module)
<b>Platform material</b>	AISI304 stainless steel	AISI304 stainless steel	AISI304 stainless steel
<b>Weighing pan material</b>	AISI304 stainless steel	AISI304 stainless steel	AISI304 stainless steel
<b>Indicator fastening</b>	cable (K)	cable (K)	cable (K)
<b>Display</b>	10.1" touch panel	10.1" touch panel	10.1" touch panel
<b>Keyboard</b>	on-screen	on-screen	on-screen
<b>Indicator type</b>	PUE HY10	PUE HY10	PUE HY10
<b>Ingress protection - platform</b>	IP 68	IP 68	IP 68
<b>Ingress protection - indicator</b>	IP 68/69	IP 68/69	IP 68/69
<b>USB</b>	1 × type A, 1 × MR 4 PIN	1 × type A, 1 × MR 4 PIN	1 × type A, 1 × MR 4 PIN
<b>RS 485</b>	1	1	1
<b>RS 232</b>	1	1	1
<b>Ethernet</b>	10 / 100 Mbit	10 / 100 Mbit	10 / 100 Mbit
<b>IN/OUT</b>	4 × IN, 4 × OUT for (IN – 5-24 VDC, OUT – max 30 VDC, 0,5 ADC)	4 × IN, 4 × OUT for (IN – 5-24 VDC, OUT – max 30 VDC, 0,5 ADC)	4 × IN, 4 × OUT for (IN – 5-24 VDC, OUT – max 30 VDC, 0,5 ADC)
<b>PROFIBUS module**</b>	DP SLAVE	DP SLAVE	DP SLAVE
<b>PROFINET Module**</b>	1 × type RJ45	1 × type RJ45	1 × type RJ45
<b>AN module**</b>	4-20mA, 0-20mA current loop; 0-10V voltage loop	4-20mA, 0-20mA current loop; 0-10V voltage loop	4-20mA, 0-20mA current loop; 0-10V voltage loop
<b>WE12 module**</b>	12IN / 12OUT - cable gland for (IN – 5-24 VDC, OUT – max 30 VDC, 0,5 ADC)	12IN / 12OUT - cable gland for (IN – 5-24 VDC, OUT – max 30 VDC, 0,5 ADC)	12IN / 12OUT - cable gland for (IN – 5-24 VDC, OUT – max 30 VDC, 0,5 ADC)
<b>Wireless Module**</b>	YES (external antenna) 802.11 b/g/n	YES (external antenna) 802.11 b/g/n	YES (external antenna) 802.11 b/g/n
<b>Power supply</b>	100 ÷ 240V AC 50÷60Hz	100 ÷ 240V AC 50÷60Hz	100 ÷ 240V AC 50÷60Hz
<b>Power consumption</b>	21 W	21 W	21 W
<b>Operating temperature</b>	+10 ÷ +40 °C	+10 ÷ +40 °C	+10 ÷ +40 °C
<b>Relative humidity ***</b>	40 ÷ 80%	40 ÷ 80%	40 ÷ 80%
<b>Transport and storage temperature</b>	-10 ÷ +50 °C	-10 ÷ +50 °C	-10 ÷ +50 °C
<b>Weighing pan dimensions</b>	400 × 600 mm	400 × 600 mm	400 × 600 mm
<b>Indicator dimensions</b>	360 × 275 × 120 mm	360 × 275 × 120 mm	360 × 275 × 120 mm
<b>Net weight</b>	23 kg	23 kg	23 kg
<b>Gross weight</b>	27.8 kg	27.8 kg	27.8 kg
<b>Platform packaging dimensions</b>	670 × 510 × 330 mm	670 × 510 × 330 mm	670 × 510 × 330 mm
<b>Indicator packaging dimensions</b>	420 × 350 × 230 mm	420 × 350 × 230 mm	420 × 350 × 230 mm

\* option: dual range weighing instrument

\*\* optional scale design

\*\*\* non-condensing conditions



## Technical Specifications

	HY10.15.H5.K	HY10.30.H5.K*	HY10.60.H5.K*
<b>Maximum capacity [Max]</b>	15 kg	30 kg	60 kg
<b>Minimum capacity</b>	100 g	200 g	400 g
<b>Readability [d]</b>	5 g	10 g	20 g
<b>Max readability for non-verified scale</b>	1 g	1 g	2 g
<b>Verification unit [e]</b>	50 g	100 g	20 g
<b>Tare range</b>	-15 kg	-30 kg	-60 kg
<b>Verification</b>	Yes	Yes	Yes
<b>OIML class</b>	III	III	III
<b>Optional quantity of weighing platforms**</b>	Maximum 6 (2 × internal weighing module + 4 × external weighing module)	Maximum 6 (2 × internal weighing module + 4 × external weighing module)	Maximum 6 (2 × internal weighing module + 4 × external weighing module)
<b>Platform material</b>	AISI304 stainless steel	AISI304 stainless steel	AISI304 stainless steel
<b>Weighing pan material</b>	AISI304 stainless steel	AISI304 stainless steel	AISI304 stainless steel
<b>Indicator fastening</b>	cable (K)	cable (K)	cable (K)
<b>Display</b>	10.1" touch panel	10.1" touch panel	10.1" touch panel
<b>Keyboard</b>	on-screen	on-screen	on-screen
<b>Indicator type</b>	PUE HY10	PUE HY10	PUE HY10
<b>Ingress protection - platform</b>	IP 68	IP 68	IP 68
<b>Ingress protection - indicator</b>	IP 68/69	IP 68/69	IP 68/69
<b>USB</b>	1 × type A, 1 × MR 4 PIN	1 × type A, 1 × MR 4 PIN	1 × type A, 1 × MR 4 PIN
<b>RS 485</b>	1	1	1
<b>RS 232</b>	1	1	1
<b>Ethernet</b>	10 / 100 Mbit	10 / 100 Mbit	10 / 100 Mbit
<b>IN/OUT</b>	4 × IN, 4 × OUT for (IN – 5-24 VDC, OUT – max 30 VDC, 0,5 ADC)	4 × IN, 4 × OUT for (IN – 5-24 VDC, OUT – max 30 VDC, 0,5 ADC)	4 × IN, 4 × OUT for (IN – 5-24 VDC, OUT – max 30 VDC, 0,5 ADC)
<b>PROFIBUS module**</b>	DP SLAVE	DP SLAVE	DP SLAVE
<b>PROFINET Module**</b>	1 × type RJ45	1 × type RJ45	1 × type RJ45
<b>AN module**</b>	4-20mA, 0-20mA current loop; 0-10V voltage loop	4-20mA, 0-20mA current loop; 0-10V voltage loop	4-20mA, 0-20mA current loop; 0-10V voltage loop
<b>WE12 module**</b>	12IN / 12OUT - cable gland for (IN – 5-24 VDC, OUT – max 30 VDC, 0,5 ADC)	12IN / 12OUT - cable gland for (IN – 5-24 VDC, OUT – max 30 VDC, 0,5 ADC)	12IN / 12OUT - cable gland for (IN – 5-24 VDC, OUT – max 30 VDC, 0,5 ADC)
<b>Wireless Module**</b>	YES (external antenna) 802.11 b/g/n	YES (external antenna) 802.11 b/g/n	YES (external antenna) 802.11 b/g/n
<b>Power supply</b>	100 ÷ 240V AC 50÷60Hz	100 ÷ 240V AC 50÷60Hz	100 ÷ 240V AC 50÷60Hz
<b>Power consumption</b>	21 W	21 W	21 W
<b>Operating temperature</b>	+10 ÷ +40 °C	+10 ÷ +40 °C	+10 ÷ +40 °C
<b>Relative humidity ***</b>	40 ÷ 80%	40 ÷ 80%	40 ÷ 80%
<b>Transport and storage temperature</b>	-10 ÷ +50 °C	-10 ÷ +50 °C	-10 ÷ +50 °C
<b>Weighing pan dimensions</b>	600 × 600 mm	600 × 600 mm	600 × 600 mm
<b>Indicator dimensions</b>	360 × 275 × 120 mm	360 × 275 × 120 mm	360 × 275 × 120 mm
<b>Net weight</b>	24.4 kg	24.4 kg	24.4 kg
<b>Gross weight</b>	28.7 kg	28.7 kg	28.7 kg
<b>Platform packaging dimensions</b>	840 × 700 × 400 mm	840 × 700 × 400 mm	840 × 700 × 400 mm
<b>Indicator packaging dimensions</b>	420 × 350 × 230 mm	420 × 350 × 230 mm	420 × 350 × 230 mm

\* option: dual range weighing instrument

\*\* optional scale design

\*\*\* non-condensing conditions

## Technical Specifications

	<b>HY10.15.H5.K</b>	<b>HY10.60.H6.K</b>	<b>HY10.150.H6.K*</b>
<b>Maximum capacity [Max]</b>	150 kg	60 kg	150 kg
<b>Minimum capacity</b>	1000 g	400 g	1000 g
<b>Readability [d]</b>	50 g	20 g	50 g
<b>Max readability for non-verified scale</b>	5 g	2 g	20 g
<b>Verification unit [e]</b>	50 g	2 g	50 g
<b>Tare range</b>	-150 kg	-60 kg	-150 kg
<b>Verification</b>	Yes	Yes	Yes
<b>OIML class</b>	III	III	III
<b>Optional quantity of weighing platforms**</b>	Maximum 6 (2 × internal weighing module + 4 × external weighing module)	Maximum 6 (2 × internal weighing module + 4 × external weighing module)	Maximum 6 (2 × internal weighing module + 4 × external weighing module)
<b>Platform material</b>	AISI304 stainless steel	AISI304 stainless steel	AISI304 stainless steel
<b>Weighing pan material</b>	AISI304 stainless steel	AISI304 stainless steel	AISI304 stainless steel
<b>Indicator fastening</b>	cable (K)	cable (K)	cable (K)
<b>Display</b>	10.1" touch panel	10.1" touch panel	10.1" touch panel
<b>Keyboard</b>	on-screen	on-screen	on-screen
<b>Indicator type</b>	PUE HY10	PUE HY10	PUE HY10
<b>Ingress protection - platform</b>	IP 68	IP 68	IP 68
<b>Ingress protection - indicator</b>	IP 68/69	IP 68/69	IP 68/69
<b>USB</b>	1 × type A, 1 × MR 4 PIN	1 × type A, 1 × MR 4 PIN	1 × type A, 1 × MR 4 PIN
<b>RS 485</b>	1	1	1
<b>RS 232</b>	1	1	1
<b>Ethernet</b>	10 / 100 Mbit	10 / 100 Mbit	10 / 100 Mbit
<b>IN/OUT</b>	4 × IN, 4 × OUT for (IN – 5-24 VDC, OUT – max 30 VDC, 0,5 ADC)	4 × IN, 4 × OUT for (IN – 5-24 VDC, OUT – max 30 VDC, 0,5 ADC)	4 × IN, 4 × OUT for (IN – 5-24 VDC, OUT – max 30 VDC, 0,5 ADC)
<b>PROFIBUS module**</b>	DP SLAVE	DP SLAVE	DP SLAVE
<b>PROFINET Module**</b>	1 × type RJ45	1 × type RJ45	1 × type RJ45
<b>AN module**</b>	4-20mA, 0-20mA current loop; 0-10V voltage loop	4-20mA, 0-20mA current loop; 0-10V voltage loop	4-20mA, 0-20mA current loop; 0-10V voltage loop
<b>WE12 module**</b>	12IN / 12OUT - cable gland for (IN – 5-24 VDC, OUT – max 30 VDC, 0,5 ADC)	12IN / 12OUT - cable gland for (IN – 5-24 VDC, OUT – max 30 VDC, 0,5 ADC)	12IN / 12OUT - cable gland for (IN – 5-24 VDC, OUT – max 30 VDC, 0,5 ADC)
<b>Wireless Module**</b>	YES (external antenna) 802.11 b/g/n	YES (external antenna) 802.11 b/g/n	YES (external antenna) 802.11 b/g/n
<b>Power supply</b>	100 ÷ 240V AC 50÷60Hz	100 ÷ 240V AC 50÷60Hz	100 ÷ 240V AC 50÷60Hz
<b>Power consumption</b>	21 W	21 W	21 W
<b>Operating temperature</b>	+10 ÷ +40 °C	+10 ÷ +40 °C	+10 ÷ +40 °C
<b>Relative humidity ***</b>	40 ÷ 80%	40 ÷ 80%	40 ÷ 80%
<b>Transport and storage temperature</b>	-10 ÷ +50 °C	-10 ÷ +50 °C	-10 ÷ +50 °C
<b>Weighing pan dimensions</b>	600 × 600 mm	800 × 800 mm	800 × 800 mm
<b>Indicator dimensions</b>	360 × 275 × 120 mm	360 × 275 × 120 mm	360 × 275 × 120 mm
<b>Net weight</b>	24.4 kg	23 kg	23 kg
<b>Gross weight</b>	28.7 kg	27.8 kg	27.8 kg
<b>Platform packaging dimensions</b>	840 × 700 × 400 mm	1250 × 820 × 270 mm	1250 × 820 × 270 mm
<b>Indicator packaging dimensions</b>	420 × 350 × 230 mm	420 × 350 × 230 mm	420 × 350 × 230 mm

\* option: dual range weighing instrument

\*\* optional scale design

\*\*\* non-condensing conditions

## Technical Specifications

	<b>HY10.300.H6.K*</b>
Maximum capacity [Max]	300 kg
Minimum capacity	2000 g
Readability [d]	100 g
Max readability for non-verified scale	10 g
Verification unit [e]	100 g
Tare range	-300 kg
Verification	Yes
OIML class	III
Optional quantity of weighing platforms**	Maximum 6 (2 × internal weighing module + 4 × external weighing module)
Platform material	AISI304 stainless steel
Weighing pan material	AISI304 stainless steel
Indicator fastening	cable (K)
Display	10.1" touch panel
Keyboard	on-screen
Indicator type	PUE HY10
Ingress protection - platform	IP 68
Ingress protection - indicator	IP 68/69
USB	1 × type A, 1 × MR 4 PIN
RS 485	1
RS 232	1
Ethernet	10 / 100 Mbit
IN/OUT	4 × IN, 4 × OUT for (IN – 5-24 VDC, OUT – max 30 VDC, 0,5 ADC)
PROFIBUS module**	DP SLAVE
PROFINET Module**	1 × type RJ45
AN module**	4-20mA, 0-20mA current loop; 0-10V voltage loop
WE12 module**	12IN / 12OUT - cable gland for (IN – 5-24 VDC, OUT – max 30 VDC, 0,5 ADC)
Wireless Module**	YES (external antenna) 802.11 b/g/n
Power supply	100 ÷ 240V AC 50÷60Hz
Power consumption	21 W
Operating temperature	+10 ÷ +40 °C
Relative humidity ***	40 ÷ 80%
Transport and storage temperature	-10 ÷ +50 °C
Weighing pan dimensions	800 × 800 mm
Indicator dimensions	360 × 275 × 120 mm
Net weight	23 kg
Gross weight	27.8 kg
Platform packaging dimensions	1250 × 820 × 270 mm
Indicator packaging dimensions	420 × 350 × 230 mm

- \* option: dual range weighing instrument  
 \*\* optional scale design  
 \*\*\* non-condensing conditions

# Dimensions

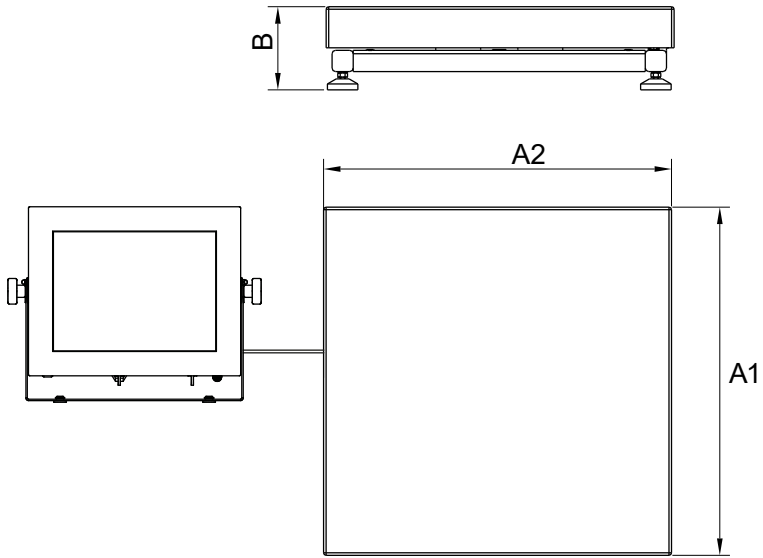

H Platform

Scale type	A1	A2	B
HY10 H1.K	200	150	85 ±3
HY10 H2.K	250	300	103 ±3
HY10 H3.K	410	410	98 ±2
HY10 H4.K	500	500	155 ±5
HY10 H5.K	600	600	155 ±5
HY10 H6.K	800	800	135 ±5

dimensions in mm

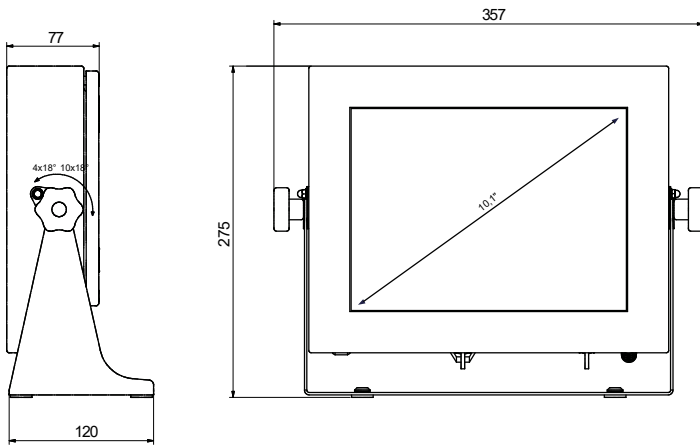

PUE HY10

## Accessories

---

### Peripheral Devices

- Epson dot matrix printer
- Zebra labellers
- WWG-2/4 large-size display
- LCD – WD-4/3 display (backlit)
- stack light
- control buttons
- transponder card scanner
- barcode scanner

### Cables, Converters

- PT0019 cable – (scale – Epson printer)
- USB – PT0087 cable (Epson printer)
- PT0022 – cable (scale - Zebra printer)
- PT0020 cable – (scale– computer)
- RS-232 – PT0326 cable (indicator– indicator)

- RS 232 – PT0348 cable (scale–HRP, MWSH, MWLH)
- Ethernet 0198 cable
- IN/OUT– PT0256 cable
- USB type A-B cable
- Ethernet cable

### Weighing Platforms

- 1 load cell platforms
- 4 load cell platforms
- high resolution platforms

### Remaining Accessories

- stands for indicators
- weighing tables

## Dedicated Software

---

### R-LAB

- collecting measurements
- carrying out statistical analysis of measurements
- customized graphs and reports

### Label Editor R02

- designing label templates
- sending graphics and fonts to label printers
- printing label templates using connected printers

### E2R PGC

- synchronization of databases, operators, products schedules
- record of measurements and PGC controls carried out on weighing instruments linked in ETHERNET network
- quality assessment of pre- packaged goods based on acquired data

### E2R Weighing Records

- complete, automated databases synchronization
- fully supported processes of labelling and parts counting
- record of weighings, weighings archiving
- basic and advanced (with graphs) reports

### E2R Formulations

- carrying out simple formulations
- support of an advanced formulations orders function
- warehouse management
- optional automatic dispensing and constant correction of the dispensing process
- control of an ingredient using the barcode scanner

### E2R Weighings

- record of measurements carried out using the weighing indicators
- online monitoring of the production lines
- weighing thresholds control
- employees working time reporting

### RAD KEY

- Establishing cooperation between a weighing instrument and a computer

### R.Barcode

- The basic function software is presentation of the data sent by barcode scanners connected to PC via USB or RS232

### Radwag Development Studio

- presentation of functions (and subfunctions) of communication protocol (Common Communication Protocol)

- possibility of connection with weighing equipment on which each function is carried out,
- library with mass control, contained within the development environment
- complete documentation of the communication protocol
- set of user manuals for different solutions addressed for programmers employed in companies using RADWAG-manufactured weighing equipment

### RADWAG Connect

- establishing communication with all balances, scales and weighing modules using Common Communication Protocol
- communication via local network,
- support of basic functions
- auto searching for devices
- connecting with few devices simultaneously, swapping between them
- clear list of connected platforms
- record of measurements in the program,
- export of carried out measurements to CSV file,
- work performed using freely selected device with Windows 10

### LabView Driver

- operation of RADWAG balances in LabView environment

### RADWAG Remote Desktop

- remote operation via computer, mobile phone or tablet
- sending text messages
- version for Windows 10 and Android systems

### Parameters Editor

- remote change of parameters
- remote on-line preview of the display
- displaying current mass indication
- software update
- file loading, editing and saving parameters to a file
- import and export of parameters
- interfaces: RS232, Ethernet and Wireless Connection.
- quick and easy edition of balance parameters using computer.

### Audit Trail Reader

- support of Audit Trail function available for 3Y, 4Y, HY10, WLY, WPY series weighing instruments
- record of operator's activity from the moment of logging in