

easySCOPE



FOREIGN BODY DETECTOR FOR PACKAGED GOODS

TECHNICAL DATASHEET

*easy*SCOPE 400

DIMENSIONS

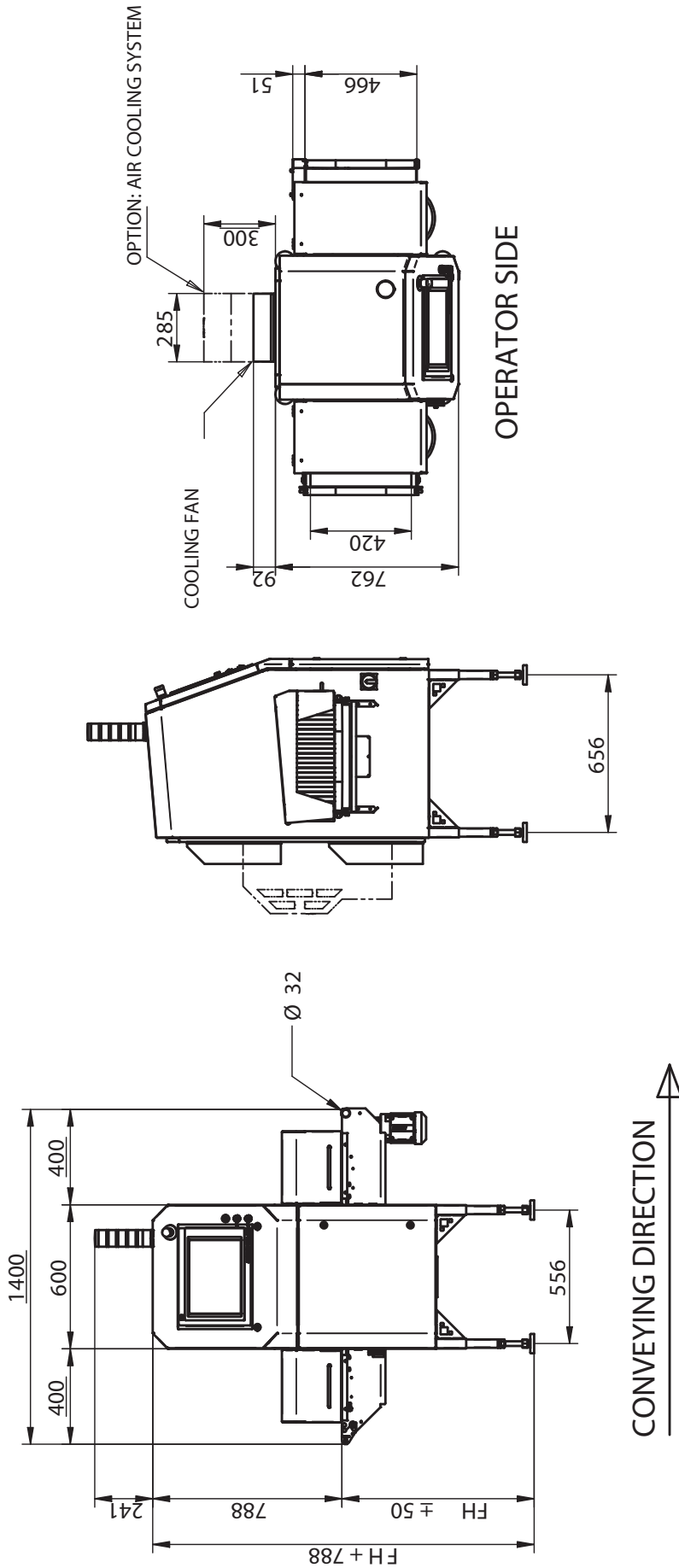

SENSITIVE AREA (RADIATION CONE)

PRODUCT HEIGHT	PRODUCT WIDTH
0	380
30	360
60	340
90	325
120	305
150	285

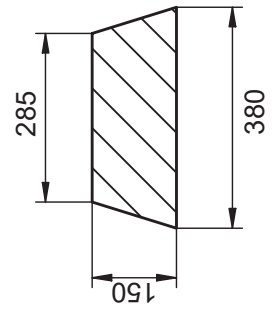

TECHNICAL DATA

■ HOUSING:	STAINLESS STEEL 304, SANDBLASTED
■ PROTECTION CLASS:	HOUSING IP 54; CONVEYOR IP 65
■ AMBIENT TEMPERATURE:	0° C TO + 28 C WITH FILTER FAN 0° C TO + 40 °C WITH AIR COOLING
■ STORAGE TEMPERATURE:	- 10°C TO + 60°C
■ RELATIVE HUMIDITY:	UP TO 90% (WITHOUT CONDENSATION WATER)
■ OPERATING VOLTAGE:	200V - 240V AC, 50-60 Hz
■ MAINS PROTECTION:	10 A
■ POWER CONSUMPTION:	670 W WITH FILTER FAN 840 W WITH AIR COOLING
■ MAINS CONNECTION:	APPROX. 3 m CABLE WITH SAFETY PLUG
■ X-RAY GENERATOR:	80 KV / 5 mA, MAX. 210 W
■ X-RAY DETECTOR:	400 MM, EFFE TIVE DIODE SIZE 0,8 mm
■ X-RAY EMISSION:	< 0,5 µSV/H
■ CONVEYING SPEED: ¹	0,1 m/s TO 1,2 m/s
■ LINE HEIGHT:	650/700/750/800/850/950 mm ±50 mm
■ BELD WIDTH:	420 mm
■ BELD MATERIAL:	POLYURETHANE, WHITE
■ LOAD:	APPROVED FOR FOOD ACCORDING TO FDA, USDA, EU MAX. 10 kg AT v = 1,2 m/s MAX. 20 kg AT v = 0,6 m/s
■ WEIGHT:	300 kg

STANDARD SCOPE OF DELIVERY

- FOREIGN BODY DETECTOR WITH INTEGRATED BELT CONVEYOR SYSTEM
- QUIC RELEASE SYSTEM FOR BELT CLEANING
- 4 COLOR LED SIGNAL TOWER
- INDUSTRIAL PC WITH 15,4" FLAT MONITOR AND TOUCH SCREEN
- HIGH PERFORMANCE IMAGING SOFTWARE
- UNINTERRUPTIBLE POWER SUPPLY
- FILTER FAN
- COMPREHENSIVE SECURITY AND CONTROL PACKAGE (SECURITY SWITCH, PLC, FREQUENCY CONVERTER, ETC .)
- USER MANUAL INCL. INSTALLATION INSTRUCTIONS, WIRING DIAGRAMM AND SPARE PARTS LIST IN SEVERAL LANGUAGES
- EC CONFORMITY DECLARATION

¹The nominal speed is ± 40 % adjustable and has to be defined for each project.

DELIVERABLE OPTIONS

- AIR COOLING SYSTEM FOR DUSTY ENVIROMENT AND AMBIENT TEMPERATURE UP TO 40°C
- WATER JET-PROTECTIVE COVERS FOR PROTECTION CLASS IP 55
- ACOUSTICAL SIGNALLING DEVICE
- REJECT SYSTEMS: PUSHER, AIR JET
- SIDE GUIDES
- LOCKABLE CONTAINER FOR REJECTED PRODUCT
- SAFETY COVER: STAINLESS STEEL OR MAKROLON
- HIGH-RESOLUTION X-RAY DETECTOR (EFFECTIVE DIODE SIZE 0,4 mm)
- CASTOR WHEELS (LINE HEIGHT 800/850/900/950 mm \pm 50 mm)



RADWAG Balances & Scales
Bracka 28, 26-616 Radom, Poland
www.radwag.com