

# User Manual

## of Postal scales

Manual number:  
ITKU-20-02-01-12-A



### MANUFACTURER OF ELECTRONIC WEIGHING INSTRUMENTS

RADWAG Wagi Elektroniczne 26 – 600 Radom Bracka 28 Street - POLAND

Phone +48 48 38 48 800, phone/fax. +48 48 385 00 10

Selling department +48 48 366 80 06

[www.radwag.com](http://www.radwag.com)

JANUARY 2012

## TABLE OF CONTENTS

<b>1. INTENDED USE</b> .....	<b>5</b>
<b>2. PRECAUTIONS</b> .....	<b>5</b>
2.1. Maintenance .....	5
2.2. Accumulator / battery pack .....	5
2.2.1. Power supply of weighing indicators in plastic casings .....	6
2.2.2. Replacement of worn batteries .....	7
2.3. Operation in a strong electrostatic field .....	8
<b>3. WARRANTY CONDITIONS</b> .....	<b>8</b>
<b>4. MAIN DIMENSIONS</b> .....	<b>9</b>
<b>5. UNPACKING AND ASSEMBLY</b> .....	<b>10</b>
5.1. Scales of WPT/P 2 series .....	10
5.2. Scales of WPT/P 60 series .....	11
<b>6. GETTING STARTED</b> .....	<b>12</b>
<b>7. KEYPAD</b> .....	<b>13</b>
<b>8. KEYS' FUNCTIONS</b> .....	<b>13</b>
<b>9. INSCRIPTIONS ON THE DISPLAY</b> .....	<b>14</b>
<b>10. USER MENU</b> .....	<b>14</b>
10.1. Submenus .....	14
10.2. Browsing user menu .....	15
10.2.1. Keypad .....	15
10.2.2. Return to the weighing mode .....	15
<b>11. WEIGHING</b> .....	<b>16</b>
11.1. Tarring .....	17
11.2. Inscribing tare value .....	17
11.3. Zeroing .....	18
11.4. Weighings in two ranges .....	18
11.5. Selection of basic weight unit .....	19
11.6. Temporarily selected unit .....	20
<b>12. MAIN PARAMETERS</b> .....	<b>21</b>
12.1. Setting a filtering level .....	21
12.2. Median filter .....	22
12.3. Autozero function .....	23
12.4. Tare function .....	24
<b>13. RS 232 PARAMETERS</b> .....	<b>25</b>
13.1. Baud rate .....	25
13.2. Minimal mass threshold .....	26
<b>14. OTHER PARAMETERS</b> .....	<b>26</b>
14.1. Backlight function .....	27
14.1.1. Backlight for supplying from mains .....	27
14.1.2. Backlight for supplying from batteries .....	28
14.2. "Beep" signal – after pressing a key .....	28
14.3. Automatic switch-off .....	29
14.4. Battery voltage level check .....	30
14.4.1. Checking the batteries .....	30
14.4.2. Battery discharge pictogram .....	31
14.4.3. Accumulator charging option .....	31
14.4.4. Formatting rechargeable battery packs .....	32

<b>15. USER CALIBRATION</b> .....	<b>33</b>
15.1. Calibration.....	33
15.2. Start mass adjustment .....	35
<b>16. COOPERATION WITH PRINTER</b> .....	<b>36</b>
<b>17. COOPERATION WITH COMPUTER</b> .....	<b>37</b>
<b>18. COMMUNICATION PROTOCOL</b> .....	<b>38</b>
18.1. General information.....	38
18.2. A set of commands for RS interfaces.....	38
18.3. Respond message format .....	39
18.4. Command's description.....	39
18.4.1. Zeroing.....	39
18.4.2. Tarring .....	39
18.4.3. Get tare value .....	40
18.4.4. Send the stable result in basic unit.....	40
18.4.5. Send the result immediately in basic unit .....	41
18.4.6. Send the stable result in current unit.....	41
18.4.7. Send the result immediately in current unit.....	42
18.4.8. Switch on continuous transmission in basic unit.....	43
18.4.9. Switch off continuous transmission in basic unit.....	43
18.4.10. Switch on continuous transmission in current unit.....	43
18.4.11. Switch off continuous transmission in current unit .....	44
18.4.12. Send all implemented commands.....	44
18.5. Manual printouts.....	44
18.6. Continuous transmission .....	45
18.7. Configuring printouts .....	45
<b>19. ERROR COMMANDS</b> .....	<b>46</b>
<b>20. TECHNICAL PARAMETERS</b> .....	<b>46</b>
<b>21. TROUBLE SHOOTING</b> .....	<b>47</b>
<b>22. ADDITIONAL EQUIPMENT</b> .....	<b>47</b>

## 1. INTENDED USE

Platform scales are designed for fast and precise measurements of weighed loads masses and direct commercial settlements. Tarring in full weighing range enables to determine net mass of weighed loads. Additional display is additional equipment of scale. It is to control mass of weighed load by another person.

### Functions:

- backlight of display
- level of filtration
- median filter
- autozero function
- setting baud rate of transmission
- designation minimum mass for function operating
- automatic tare
- memory of tare
- inscribing tare value
- automatic scale switch-off
- user calibration

## 2. PRECAUTIONS

### 2.1. Maintenance

- A. Please, read carefully this user manual before and use the device according to its intended use.
- B. Devices that are to be withdrawn from usage should be sent back to the producer or in case of own utilization do it according to the law.

### 2.2. Accumulator / battery pack

Scales equipped with indicator **PUE C/31** (plastic casing) are devices designed to be supplied from **NiMH** batteries (nickel-metal-hydrogen) with rated voltage of **1.2V**, size **R6** and capacities from **1800** to **2800mAh** charged while connected to mains without stopping operation.

The device connected to mains intelligently monitors the battery state and charges it if possible. After sudden lack of power supply from the mains the device automatically switches to accumulator without breaking operation.



**In case of an elongated storage period in low temperatures, it is not allowed the full discharge of the accompanied batteries.**



**The equipment including accumulators does not belong to your regular household waste. The European legislation requires that electric and electronic equipment be collected and disposed separately from other communal waste with the aim of being recycled.**

**Notice:**

*Some symbols on accumulators identify harmful elements/compounds:*

*Pb = lead,*

*Cd = cadmium,*

*Hg = mercury.*

### **2.2.1. Power supply of weighing indicators in plastic casings**

Indicators in plastic casing are intended to be supplied from a power adapter or from NiMH rechargeable battery pack (standard equipment). New rechargeable batteries should be formatted according to the description in the chapter 14.4.4. of this manual.

Alternatively, you can use to power the device R6 size standard non-rechargeable batteries. If you want to use normal batteries instead of rechargeable ones, proceed as follows:

- Before installing non-rechargeable batteries turn on the device and set **<5.5.Chr6>** to **<no>**, to switch off charging.
- Then install the batteries.



**Installing batteries without changing **<5.5.Chr6>** to **<no>** may cause damage of batteries and the indicator.**

### 2.2.2. Replacement of worn batteries

Users have the ability to replace worn out batteries to new ones in weighing indicators **PUE C/31** (plastic casing).

#### Procedure:

- Open the lid of the chamber for batteries placed in the bottom of the indicator casing:

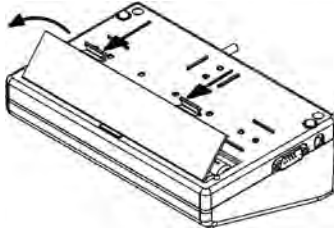

- Remove discharged and then insert new batteries into the chamber, according to given polarity (+/-):

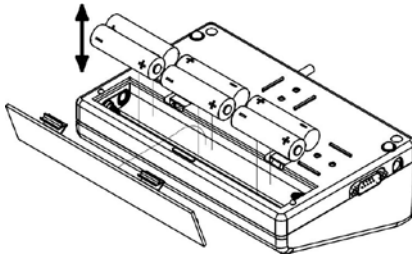

- Close the lid of the chamber for batteries:

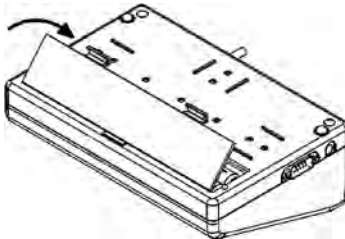



**In PUE C/31H and PUE C/31H/Z weighing indicators (stainless steel housing) the worn out accumulator can be exchanged to a new one by the authorized service of the manufacturer.**

### **2.3. Operation in a strong electrostatic field**

If the device is about to operate in a strong electrostatic field (e.g. printing houses etc.) it should be connected to the earthing. Connect it to the clamp terminal signed  $\perp$ .

## **3. WARRANTY CONDITIONS**

- A. RADWAG is obliged to repair or change those elements that appears to be faulty because of production and construction reason,
- B. Defining defects of unclear origin and outlining methods of elimination can be settled only in participation of a user and the manufacturer representatives,
- C. RADWAG does not take any responsibility connected with destructions or losses derives from non-authorized or inappropriate (not adequate to manuals) production or service procedures,
- D. Warranty does not cover:
  - Mechanical failures caused by inappropriate maintenance of the device or failures of thermal or chemical origin or caused by atmospheric discharge, overvoltage in mains or other random event,
  - Inappropriate cleaning.
- E. Loss of warranty appears after:
  - Access by an unauthorized service,
  - Intrusion into mechanical or electronic construction of unauthorized people,
  - Removing or destroying protection stickers.
- F. The detailed warranty conditions one can find in warranty certificate.



- G. Contact with the central authorized service:  
+48 48 384 88 00 ext. 106 or 107.

#### 4. MAIN DIMENSIONS

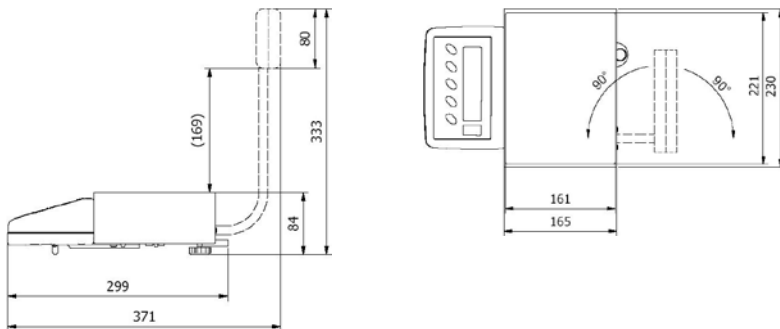

*Scales of WPT/P 2 series*

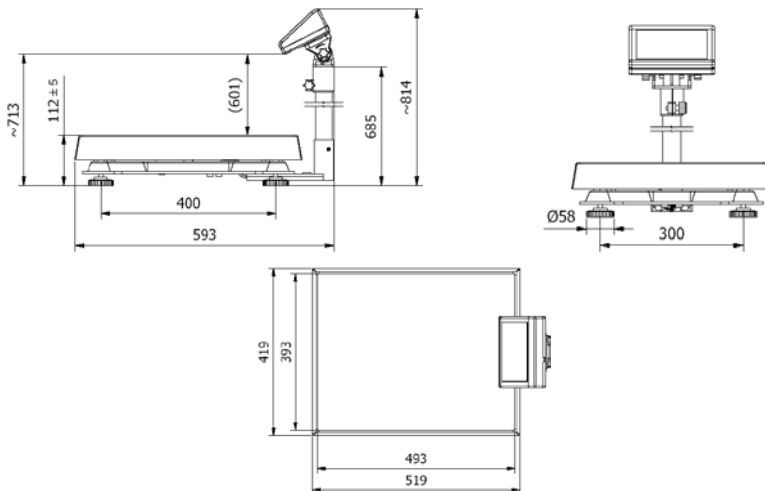

*Scales of WPT/P 60 series*

## 5. UNPACKING AND ASSEMBLY

### 5.1. Scales of WPT/P 2 series

Unpack and put the scale on a flat even stable surface far away from sources of heat and then:

- Remove transport protection:



- Set the pillar with additional display vertically:

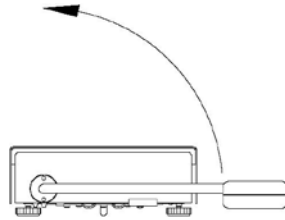

- Screw down the pillar to the scale basis:

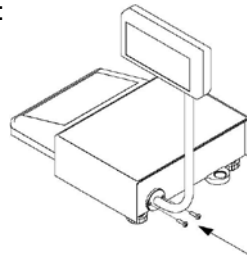

- Turn the display head:

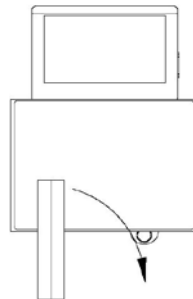

## 5.2. Scales of WPT/P 60 series

Unpack and put the scale on a flat even stable surface far away from sources of heat and then:

A. Remove transport protection:

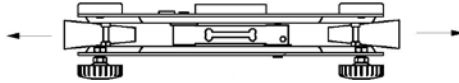

B. To attach the pillar to the scale body:

- Screw down the pillar handler to the platform:

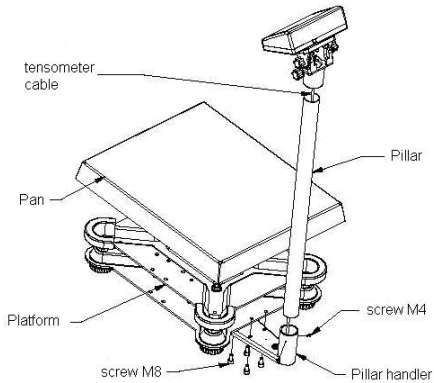

- Stretch delicately the cable so it did not touch the ground after mounting:

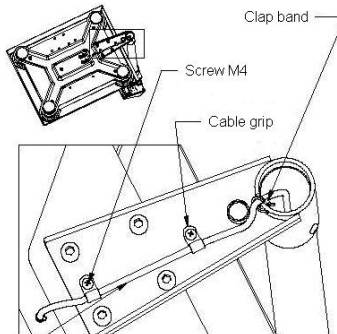

- The surplus cable wind and place inside the pillar as show below:

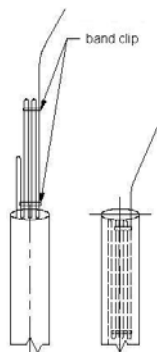

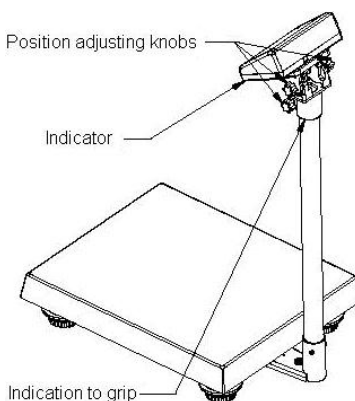

Put the indicator with the hendler on the pillar and tighten up the handwheels:

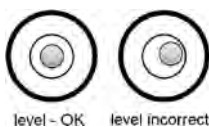

## 6. GETTING STARTED

- After unpacking and mounting the scale level it out. Use levelling legs and the level condition indicator installed in the basis of the scale.



- Turn the device on using the  key – keep pressing the key for about 0.5 sec,
- Wait for the test completion,

- Then you will see **zero indication** and pictograms:

 - zero indication

 - stable result

**kg** - weight unit

- If the indication is not zero press  key.

## 7. KEYPAD

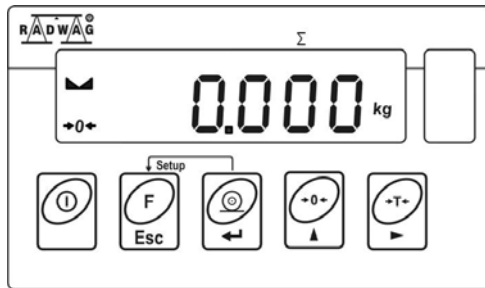

## 8. KEYS' FUNCTIONS



Switching on/off



Function key (operation mode selection)



Sending a weighing result to RS232





Zeroing





Tarring

### **Notice:**



After pressing  +  keys' functions changes. The way of operation in this mode is described in details further in this manual.

## 9. INSCRIPTIONS ON THE DISPLAY

No	Text string	Description
1.	<b>FIL</b>	Filter level
2.	<b>bAud</b>	Transmission baud rate
3.	<b>Auto</b>	Autozero correction
4.	<b>t1</b>	Power save – time to switch off while no operation
5.	<b>-0-</b>	Indication in autozero zone (indication = exact zero)
6.		Stable result (ready to read)
7.	<b>kg (g)</b>	Operation mode – weighing
8.		Rechargeable battery pack or battery discharged (BAT-LO)
9.	<b>Net</b>	Tare function has been used.

## 10. USER MENU

### 10.1. Submenus

User's menu is divided into **5** basic submenus. Each group has its own characteristic name preceded by the letter **P** and a number.

#### **P1 rEAd**

P 1.1	Fil		2
P 1.2	Auto		YES
P 1.3	tArA		no
P 1.4	Fnnd		no

#### **P2 Prnt**

P2.2	S_Lo		
P2.3	bAud		9600

#### **P3 Unit**

P3.1	StUn		kg
------	------	--	----

#### **P5 othr**

P5.1	bL		Auto
P5.2	bLbt		70
P5.3	bEEP		YES
P5.4	t1		Auto
P5.5	CHr6		YES

#### **P6 CAL**

P6.1	St_u		* FUNKCJA *
P6.2	uCAL		* FUNKCJA *

## 10.2. Browsing user menu

Use scale's keys to move inside the menu.

### 10.2.1. Keypad



Entering main menu

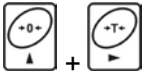

+



Inscribing tare value  
Increasing a digit value by „1”  
moving down in the menu



+



Battery / accumulator state monitoring



+



Toggling between gross / net values



Selecting the parameter or changing the value of a  
selected parameter



Entering the selected submenu or activating a parameter  
for changes



Confirmation (enter)





Leaving without changes or reaching a higher level of the  
menu

### 10.2.2. Return to the weighing mode



The changes that have been introduced should be saved  
in order to keep them in the memory for good.

While leaving parameters press  key until the text

**<SAuE?>** appears on the display. Then press: 

– to save changes or  – to leave without changes.

## 11. WEIGHING

Put a load you want to weigh on the weighing pan. When the  pictogram appears it means that the result is stable and ready to read. In order to assure long-term operation and appropriate measurements of weighted loads following precautions should be taken into consideration:

- Loads should be placed on the pan delicately and carefully in order to avoid mechanical shocks:

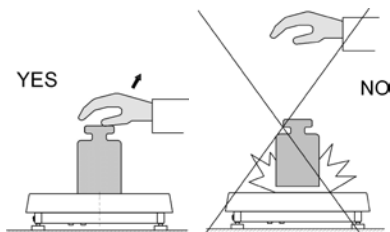

- Loads should be placed centrally on the pan (errors caused by eccentric weighing are outlined by standard PN-EN 45501 ch. 3.5 and 3.6.2):

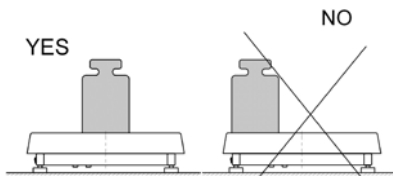

- Do not load the pan with concentrated force:

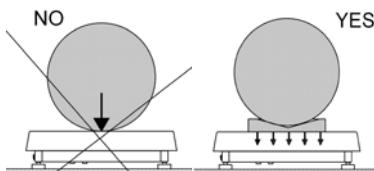

- Avoid side loads, particularly side shocks should be avoided

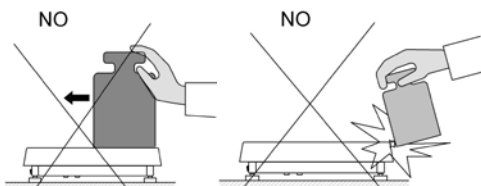



## 11.1. Tarring

In order to determine the net mass put the packaging on the pan.

After stabilising press  (**Net** pictogram will be displayed in the left upper corner and zero will be indicated).

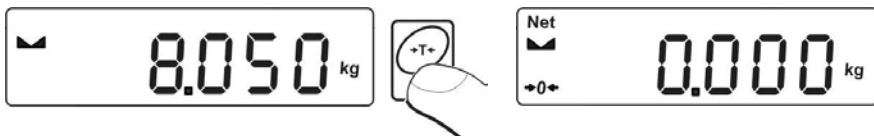

After placing a load on the weight pan net mass will be shown. Tarring is possible within the whole range of the scale. After unloading the pan the display shows the tared value with minus sign.





### **Notice:**



*Tarring cannot be performed when a negative or zero value is being displayed. In such case **Err3** appears on the display and short audible signal will be emitted.*

## 11.2. Inscribing tare value

You can also inscribe a tare value. While in weighings mode press:

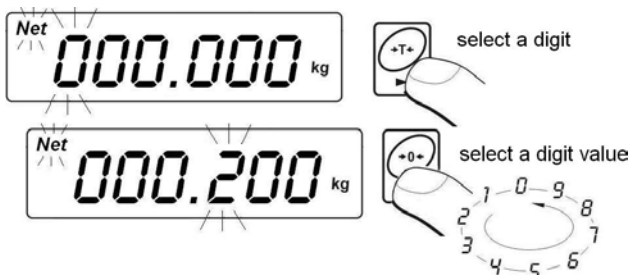
- Press simultaneously  and ,
- You will see :



- Using  and  set the tare value,
- Press ,
- Program returns to weighings mode. The inscribed tare value can be seen on the display with „-“ sign,
- Tare can be inscribed anytime in weighings mode.

**Notice:**

*You cannot inscribe a new tare value when the tare value in memory is greater than zero. In the case of trying this the <Err3> message will be displayed and short audible signal will be emitted.*

### 11.3. Zeroing

To **ZERO** the scale press: .

The scale will display zero and following pictograms:  $\rightarrow 0 \leftarrow$  and .

Zeroing is only possible within the scope of  $\pm 2\%$  of full scale.

While zeroing outside the scope of  $\pm 2\%$  you will see **Err2**.

Zeroing is possible only in stable state.

**Notice:**

*Zeroing is possible only within the  $\pm 2\%$  interval of the maximal range. If zeroing is performed beyond this range the <Err2> message and short audible signal will be emitted.*

### 11.4. Weighings in two ranges

Switching between the **I range** and the **II range** happens automatically (exceeding Max of the **I range**). Weighings in the second range is signalled by a pictogram in the top left corner of the display.

Then weighings is done with the accuracy of the **II range** to the moment of returning to zero (autozero range  $\rightarrow 0 \leftarrow$ ) where the scale switches back to the **I range**.

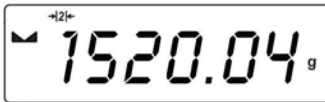



### 11.5. Selection of basic weight unit

This function is used to set weight unit the scale will start with.

#### Procedure:

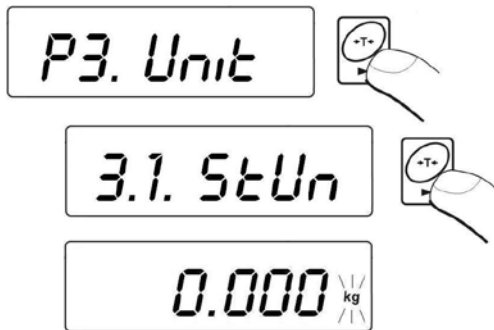
- Enter the submenu **<P3.Unit>** and then:



- press , until the expected unit appears on the display:



#### Options:

- When the basic unit is [kg], users can toggle between: [kg, lb, N], *for verified scales [lb] is not accessible*,
- If the basic unit is [g], users can toggle between: [g, ct, lb], *for verified scales [lb] is not accessible*,

- After you select the unit press , the scale returns to:

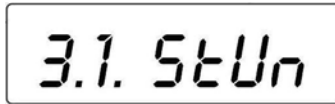

- Return to weighing according to chapter - 10.2.2.

**Notice:**

*After turning on the scale always sets the basic unit.*

**11.6. Temporarily selected unit**

This function is used to set weight unit the scale will use temporarily until the next power off or next selection.

**Procedure:**

- Press  and then:

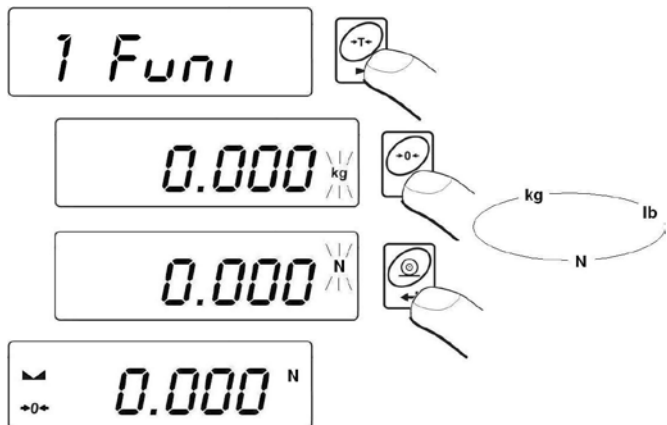

- After you select the unit you want come back to weighing procedure.

## Options:

- A. When [kg] is a basic unit, users can select following units:  
[kg, lb, N], [*lb*] is not accessible for verified scales.
- B. When [g] is a basic unit, users can select following units:  
[g, ct, lb], [*lb*] is not accessible for verified scales.

## 12. MAIN PARAMETERS

Users can adjust the scale to external ambient conditions (filtering level) or particular needs (autozero operation, tare memory). This parameters are placed in <P1.rEAd> submenu.

### 12.1. Setting a filtering level

#### Procedure:

- Enter the submenu <P1.rEAd> and then:

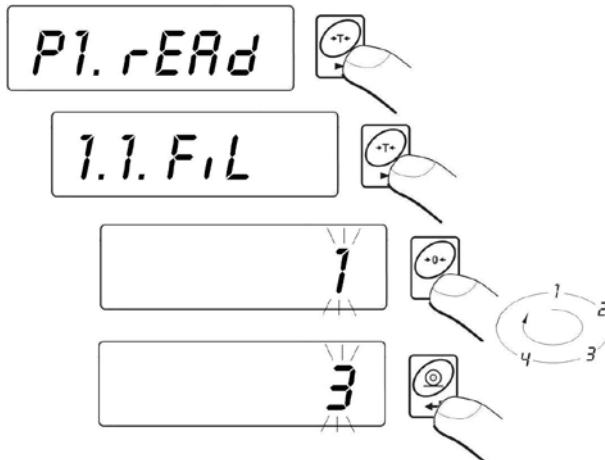

1 - 4 - level of filtering

- By pressing  select the filtering level you need.

**Notice:**

*Filtering level influences the time of stabilization. The higher the filtering level is the longer stabilization time is needed.*

**Return to weighing:**

See - 10.2.2.

**12.2. Median filter**

This filter eliminates short changes (impulses) of measure signal (e.g. shocks).

**Procedure:**

- Enter the submenu **<P1.rEAd>** and then:

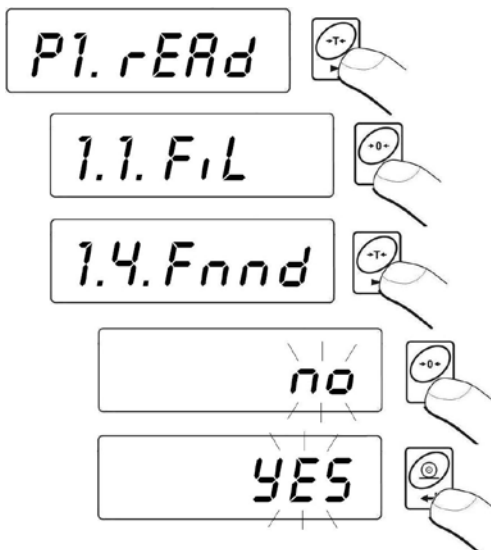



**Fnnd no** - filter disabled  
**Fnnd YES** - filter enabled

**Return to weighing:**

See - 10.2.2.

### 12.3. Autozero function

The autozero function has been implemented in order to assure precise indications. This function controls and corrects „0” indication. While the function is active it compares the results continuously with constant frequency. If two sequential results differ less than the declared value of autozero range, so the scale will be automatically zeroed and the pictograms  and  0  will be displayed.

When AUTOZERO is disabled zero is not corrected automatically. However, in particular cases, this function can disrupt the measurement process e.g. slow pouring of liquid or powder on the weighing pan. In this case, it is advisable to disable the autozero function.

#### Procedure:

- Enter the submenu **<P1.rEAd>** and then:

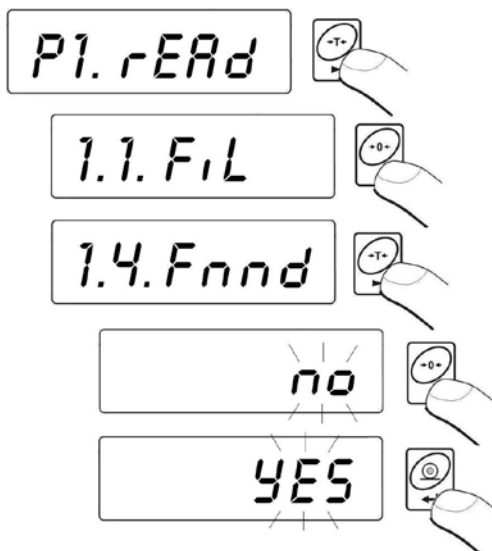

**Fnnd**    **no**    - filter disabled  
**Fnnd**    **YES**    - filter enabled

#### Return to weighing:

See - 10.2.2.

## 12.4. Tare function

This parameters enables users to configure a tare function.

### Procedure:

- Enter the submenu **<P1.rEAd>** and then:



- tArA AtAr** - **automatic tare function on** and is stored in balance memory after unplugging it from mains
- tArA no** - **automatic tare function off**
- tArA tArF** - **tare memory function** – stores last value of tare in balance memory. It is automatically displayed after starting the balance. Value of tare is displayed with minus sign, and there is **Net** symbol indicated on the display.

### Return to weighing:

See - 10.2.2.



## 13. RS 232 PARAMETERS

External devices connected to RS 232C have to be supplied from the same mains and common electric shock protection. It prevents from appearing a potential difference between zero leads of the two devices. This notice does not apply to the devices that do not use zero leads.

### Transmission parameters:

- Baud rate - 2400 – 38400 bit / s
- Data bits - 8
- Stop bits - 1
- Parity control - no

### 13.1. Baud rate

#### Procedure:

- Enter the submenu <P2.Prnt> and then:

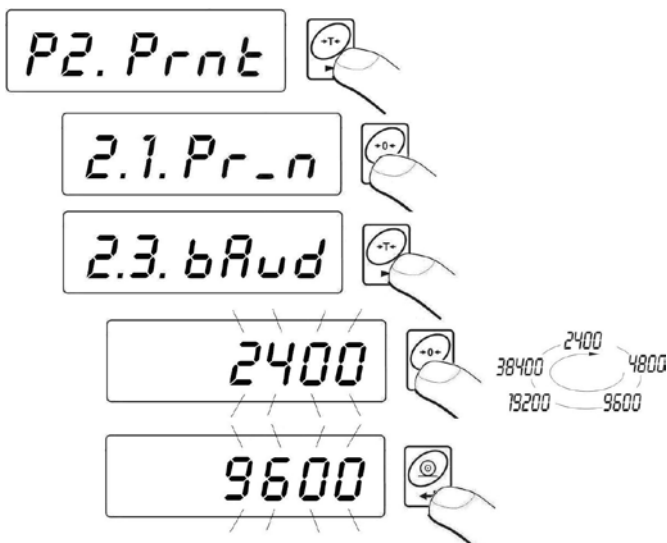

**Return to weighing:**

see 10.2.2.

### 13.2. Minimal mass threshold

This function is necessary while working with automatic tare. Automatic taring will not be applied until the indication (gross) is lower than the value inscribed in **S\_Lo** parameter.

#### Procedure:

- Enter the submenu **<P2.Prnt>** and then:

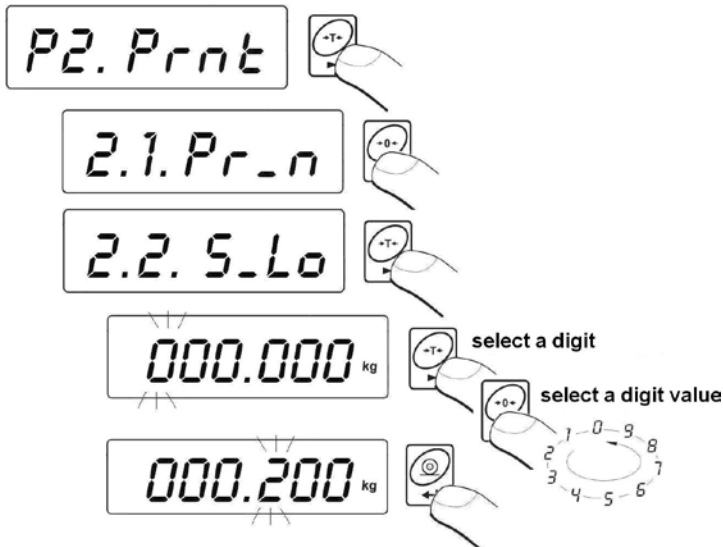

**Return to weighing:**  
see 10.2.2.

### 14. OTHER PARAMETERS

The user can set parameters which influence the scale operation. They are gathered in the submenu **<P5.othr>** e.g. backlight and beep signal. Enter this submenu **<P5.othr>** according to chapter 10.2.

## 14.1. Backlight function

Program recognises the way the scale is supplied (mains, battery) and automatically selects the way of operating on the backlight:

- bl** – for mains,
- blbt** – for batteries or rechargeable battery pack.

### 14.1.1. Backlight for supplying from mains

**Procedure:**

- Enter the submenu **<P5.othr>** and then:

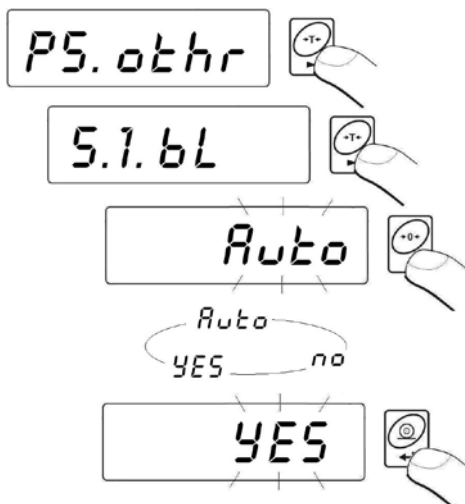

- bl no** - backlight switched off
- bl YES** - backlight switched on
- bl Auto** - backlight switched off automatically if indication becomes stable for about 10s

**Return to weighing:**

See 10.2.2.

**Notice:**

When **bl=Auto**, and the indication has not changed for 10s, the backlight is automatically switched off. The backlight is switched on again automatically after the result changes.

### 14.1.2. Backlight for supplying from batteries

The user can change the intensity of backlight from 0% to 100%. The lower the intensity is the longer the scale operates without recharging or exchanging batteries. When the intensity is set this function works as AUTO (described above).

#### Procedure:

- Enter the submenu <P5.othr> and then:

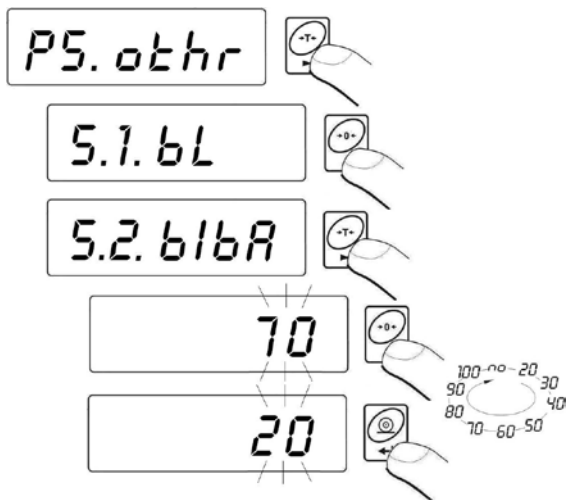

#### Return to weighing:

See 10.2.2.

#### Notice:

*The more intense the backlight is the shorter the scale operates on batteries.*

### 14.2. “Beep” signal – after pressing a key

#### Procedure:

- Enter the submenu <P5.othr> and then:

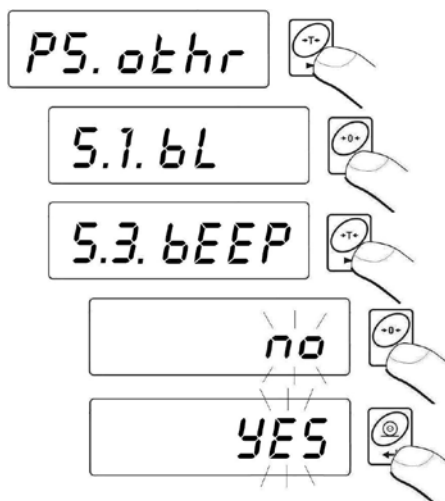

**bEEP**    **no**    - switched off  
**bEEP**    **YES**    - switched on

**Return to weighing:**  
 See 10.2.2.

### 14.3. Automatic switch-off

This function is essential to save the battery power. The scale is switched off automatically when (function **t1 = YES**) no weighing appears in 5 minutes. (no changes on the display). In case when this function disrupts the operation (e.g. long time weighing procedures) or while working with connection to mains, switch off this function.

#### Operation according to the power supply:

Setting	Operation	
	Mains	Batteries/accumulator
t1 = 0	disabled	disabled
t1 = YES	enabled	enabled
t1 = Auto *	disabled	enabled

\* automatic enabling/disabling according to the source of power.

**Procedure:**

- Enter the submenu **<P5.othr>** and then:

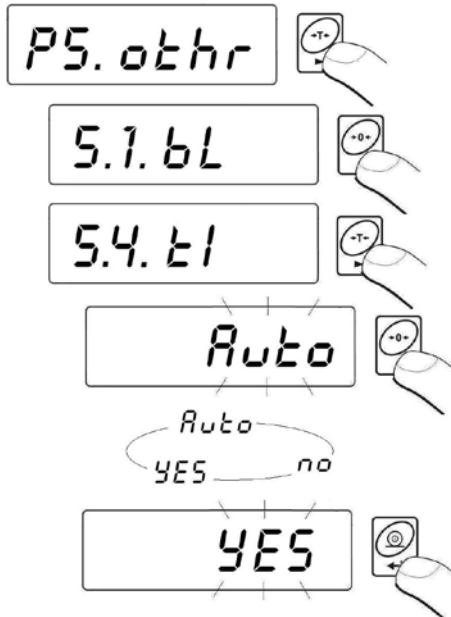

**Return to weighing:**

See 10.2.2.

**14.4. Battery voltage level check**

While supplying from batteries too low level of voltage is measured by software the pictogram  is displayed. It means that charging or exchanging batteries is required.

**14.4.1. Checking the batteries**

This function is to check the level of battery supply. It works only if:

- Weighing mode is set,
- Battery supply is set in parameters.

**Procedure:**

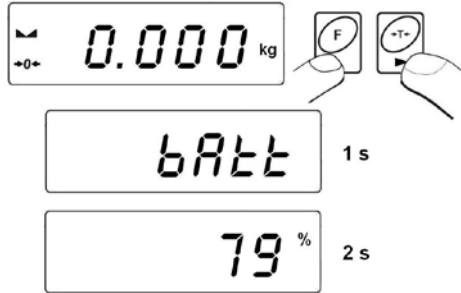



After displaying the level of batteries (in per cents) the program returns to weighing.

**14.4.2. Battery discharge pictogram**

The symbol (bat low) switches on when the voltage level drops to 18% of the accepted level of voltage. It means that charging or exchanging batteries is required.

Low level of batteries:

- Pictogram  on the display,
- After one time the device will automatically switch off to protect the batteries from destructable discharging,
- Charging is signalled by  (blinking period about 2 seconds) on the display.

**14.4.3. Accumulator charging option**

This function allows to switch on charging algorithm for **NiMH** batteries (for indicators plastic casing):

a) Parameter **<CHR6>** set to **<no>**:

- Pictogram  does not appear, charging disabled,
- During software initializing, after turning on „bAtt”.

b) Parameter **<CHR6>** set to **<YES>**:

- Pictogram  blinks slowly (period about 2 seconds), charging is enabled,

- Message „nlmh” appears on the display,
- In case of damaging accumulators or lack of it the pictogram  blinks quickly (period about 0.5 sec).

**Notice:**

Indicators are equipped with the set of rechargeable batteries NiMH R6 (AA) and power adapter.

**Procedure:**

- Enter the submenu <P5.othr> and then:

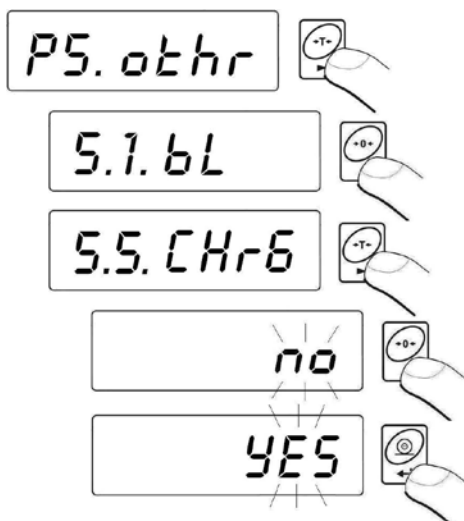

**CHr6 YES** - enabled  
**CHr6 no** - disabled

**Return to weighing:**

See 10.2.2.

**14.4.4. Formatting rechargeable battery packs**

Postal scales with indicators in plastic cases are intended to supply from power adapters (standard equipment). It is possible to supply them from NiMH AA/R6 rechargeable batteries or R6 batteries.



They need formatting after first powering up. It is crucial for batteries lifetime to undertake this process. Formatting consist in charging and total discharging (without meantime charging).

**Procedure:**

1. Supply the indicator from mains.
2. Charge batteries for 12 hours (time of charging 2200mAh batteries).
3. After 12 hours unplug from mains.
4. Use the device up to the moment of self powering down.
5. Repeat the process of charging starting from point 1.

**Notice:**

*They reach their optima capacity after three cycles of full charging and discharging.*

## 15. USER CALIBRATION

*Only for non-verified scales*

Confirmation of high accuracy of weighing requires periodical correcting of calibration factors in the scale memory – this is adjustment of the scale. Calibration should be performed when we start weighing or dynamic change of temperature occurs. Before starting calibration remove loads from the pan.

### 15.1. Calibration

**Procedure:**

- Enter the submenu **<P6.CAL>** and then:

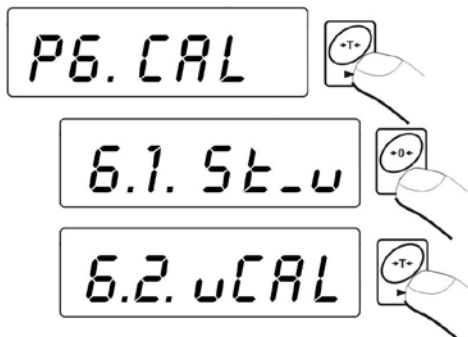

- Following inscriptions will appear

noCAL

LoAd

3.000<sup>kg</sup>

- A new start mass is adjusted during this period of time. After that a mass of calibration weight is shown (e.g. 3 000kg).
- Put a weight of the displayed mass value on the pan and press . The calibration process will start which is signalled by the message:

CAL

- After completion of the process of calibration the following screen will appear:

unLoAd

- Take off the weight , then the following sequence of screens will appear:

donE

6.2. uCAL

- Calibration process can be terminated anytime by pressing  which is signalled by the following message on the display:

Abort

- Return to weighing performing the procedure of saving parameters.

**Caution:**

If the calibration process (span adjustment) lasts longer than 15 the <Err8> message will be displayed and short audible signal will be

emitted. Press  to perform calibration again with more stable ambient conditions!

**15.2. Start mass adjustment**

If the scale does not require the full calibration process it is possible to adjust only a new start mass.

**Procedure:**

- Enter the submenu <P6.CAL> and then:

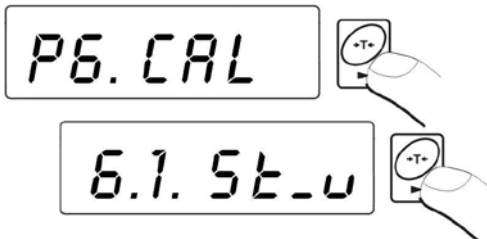

- The display will show the following information:



- After the completion of the start mass adjustment the following screen will appear:

6.1. St\_u

- The process of start mass adjustment can be terminated by pressing



, which is signalled on the display:

Abort

- Return to weighing performing the procedure of saving parameters.

### **Caution:**

*If the start mass adjustment lasts longer than 15 the <Err8> message will be displayed and short audible signal will be emitted. Press  to perform calibration again with more stable ambient conditions!*

## **16. COOPERATION WITH PRINTER**

Each time the  key is pressed a current mass value together with mass units is sent to RS 232 interface. One of thermal printer in **KAFKA** series can cooperate with each platform scales:

- KAFKA**  
Only result of weighing with mass unit can be printed.
- KAFKA 1/Z**  
This printer is equipped with an internal real time clock. Both date and time can be printed.
- KAFKA SQ S**  
This printer is equipped with an internal real time clock and possibility of running statistics from measurements. Statistic contents: quantity of samples, sum of masses of all samples, average value, standard deviation, variation factor, min value, max value, difference max - min.

## Cable diagrams:

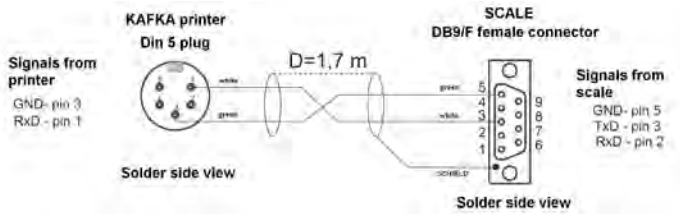

*Cable drawing scale - printer (Kafka)*

## 17. COOPERATION WITH COMPUTER

Sending weighing results to the computer can be done:

- manually
- in continuous way
- on the request from the computer
- after pressing  key,
- after sending an control command
- After sending a control command

These scales can cooperate with „**EDYTOR WAG**” program. The indicator window comprises the most important information from the scale display. The program allows to configure easily, e.g. design printouts, edit parameters. A precise description is issued in the „Help” file that accompanies the program.

## Cable diagrams:

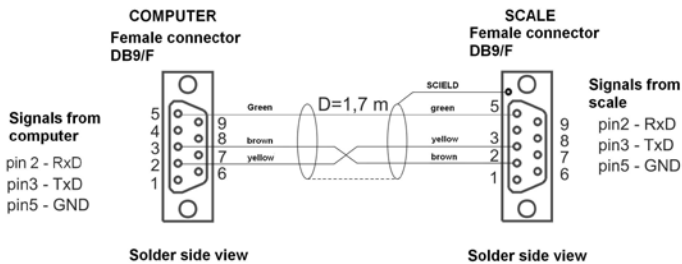

*Cable drawing connecting scale and computer*

## 18. COMMUNICATION PROTOCOL

### 18.1. General information

- A. A character protocol scale-terminal has been designed for communication between RADWAG scales and external devices via RS-232 interface.
- B. It consists of commands sent from an external device to the scale and a responses from a scale.
- C. Responses are sent every time after receiving a command (reaction for any command).
- D. Using commands allows users to receive some information about the state of scale and/or influence the operation e.g.:
  - Requesting weighing results,
  - Display control,

### 18.2. A set of commands for RS interfaces

Commands	Description of commands
Z	Zeroing
T	Tarring
TO	Get tare
S	Send the stable result in basic unit
SI	Send the result immediately in basic unit
SU	Send the stable result in current unit
SUI	Send the result immediately in current unit
C1	Switch on continuous transmission in basic unit
C0	Switch off continuous transmission in basic unit
CU1	Switch on continuous transmission in current unit
CU0	Switch off continuous transmission in current unit
PC	Send all implemented commands

#### **Notice:**

1. *Each command have to be terminated in CR LF;*
2. *The best Policy for communication is not sending another command until the former answer has been received.*

### 18.3. Respond message format

After sending a request message you can receive:

<b>XX_A CR LF</b>	command accepted and in progress
<b>XX_D CR LF</b>	command completed (appears only after XX_A)
<b>XX_I CR LF</b>	command comprehended but cannot be executed
<b>XX_^ CR LF</b>	command comprehended but time overflow error appeared
<b>XX_v CR LF</b>	command comprehended but the indication below the
<b>XX_OK CR LF</b>	Command done
<b>ES CR LF</b>	Command not comprehended
<b>XX_E CR LF</b>	error while executing command – time limit for stable result exceeded (limit time is a descriptive parameter of the scale)

**XX** - command name  
**\_** - substitutes spaces

### 18.4. Command's description

#### 18.4.1. Zeroing

Syntax **Z CR LF**

Possible answers:

**Z\_A CR LF** - command accepted and in progress  
**Z\_D CR LF** - command completed  
**Z\_A CR LF** - command accepted and in progress  
**Z\_^ CR LF** - command comprehended but zero range overflow appeared  
**Z\_A CR LF** - command accepted and in progress  
**Z\_E CR LF** - time limit for stable result exceeded  
**Z\_I CR LF** - command comprehended but cannot be executed

#### 18.4.2. Tarring

Syntax: **T CR LF**

Possible answers:

- T\_A CR LF** - command accepted and in progress
- T\_D CR LF** - command completed
  
- T\_A CR LF** - command accepted and in progress
- T\_v CR LF** - command comprehended but tare range overflow appeared
  
- T\_A CR LF** - command accepted and in progress
- T\_E CR LF** - time limit for stable result exceeded
  
- T\_I CR LF** - command comprehended but cannot be executed

### 18.4.3. Get tare value

Syntax: **TO CR LF**

Possible answers:

**TO\_TARA CR LF** - command executed

Frame format:

1	2	3	4	5-6	7-15	16	17	18	19	20	21
T	O	space	stability	space	tare	space	unit			CR	LF

**Tare** - 9 characters with decimal point justified to the right

**Unit** - 3 characters justified to the left

### 18.4.4. Send the stable result in basic unit

Syntax: **S CR LF**

Possible answers:

- S\_A CR LF** - command accepted and in progress
- S\_E CR LF** - time limit for stable result exceeded
  
- S\_I CR LF** - command comprehended but cannot be executed
  
- S\_A CR LF** - command accepted and in progress
- MASS FRAME** - mass value in basic unit is returned



**Frame format:**

1	2-3	4	5	6	7-15	16	17	18	19	20	21
S	space	stability	space	sign	mass	space	unit			CR	LF

**Example:**

**S CR LF** – computer command

**S \_ A CR LF** - command accepted and in progress

**S \_ \_ \_ \_ - \_ \_ \_ \_ \_ 8 . 5 \_ g \_ \_ CR LF** – command done, mass value in basic unit is returned.

**18.4.5. Send the result immediately in basic unit**

Syntax: **SI CR LF**

Possible answers:

**SI\_I CR LF** - command comprehended but cannot be executed at the moment

**MASS FRAME** - mass value in basic unit is returned

**Frame format:**

1	2	3	4	5	6	7-15	16	17	18	19	20	21
S	I	space	stability	space	sign	mass	space	unit			CR	LF

**Example:**

**S I CR LF** – computer command

**S I \_ ? \_ \_ \_ \_ \_ 1 8 . 5 \_ k g \_ CR LF** - command done, mass value in basic unit is returned immediately.

**18.4.6. Send the stable result in current unit**

Syntax: **SU CR LF**

Possible answers:

- SU\_A CR LF** - command accepted and in progress
- SU\_E CR LF** - timeout while waiting for stable results
- SU\_I CR LF** - command comprehended but cannot be executed
- SU\_A CR LF** - command accepted and in progress
- MASS FRAME** - mass value in current unit is returned

**Frame format:**

1	2	3	4	5	6	7-15	16	17	18	19	20	21
S	U	space	stability	space	sign	mass	space	unit			CR	LF

**Example:**

**S U CR LF** – computer command

**S U \_ A CR LF** - command accepted and in progress

**S U \_ \_ \_ - \_ \_ 1 7 2 . 1 3 5 \_ N \_ \_ CR LF** - command done, mass value in current unit is returned.

**18.4.7. Send the result immediately in current unit**

Syntax: **SUI CR LF**

Possible answers:

**SUI\_I CR LF** - command comprehended but cannot be executed

**MASS FRAME** - mass value in current unit is returned immediately

**Frame format:**

1	2	3	4	5	6	7-15	16	17	18	19	20	21
S	U	I	stability	space	sign	mass	space	unit			CR	LF

**Example:**

**S U I CR LF** – computer command

**S U I ? \_ - \_ \_ \_ 5 8 . 2 3 7 \_ k g \_ CR LF** - command executed and mass returned

#### 18.4.8. Switch on continuous transmission in basic unit

Syntax: **C1 CR LF**

Possible answers:

**C1\_I CR LF** - command comprehended but cannot be executed

**C1\_A CR LF** - command comprehended and in progress

**MASS FRAME** - mass value in basic unit is returned

**Frame format:**

1	2	3	4	5	6	7-15	16	17	18	19	20	21
S	I	space	stability	space	sign	mass	space	unit			CR	LF

#### 18.4.9. Switch off continuous transmission in basic unit

Syntax: **C0 CR LF**

Possible answers:

**C0\_I CR LF** - command comprehended but cannot be executed

**C0\_A CR LF** - command comprehended and executed

#### 18.4.10. Switch on continuous transmission in current unit

Syntax: **CU1 CR LF**

Possible answers:

**CU1\_I CR LF** - command comprehended but cannot be executed

**CU1\_A CR LF** - command comprehended and in progress

**MASS FRAME** - mass value in current unit is returned

**Frame format:**

1	2	3	4	5	6	7-15	16	17	18	19	20	21
S	U	I	stability	space	sign	mass	space	unit			CR	LF

### 18.4.11. Switch off continuous transmission in current unit

Syntax: **CU0 CR LF**

Possible answers:

**CU0\_I CR LF** - command comprehended but cannot be executed

**CU0\_A CR LF** - command comprehended and executed

### 18.4.12. Send all implemented commands

Syntax: **PC CR LF**

Possible answers:

**PC\_->\_Z,T, TO,S,SI,SU,SUI,C1,C0,CU1,CU0,PC** – command executed, the indicator have sent all the implemented commands.

## 18.5. Manual printouts

Users can general manual or automatic printouts from the scale. Manual printouts can be performed after loading the pan and stabilizing indication by pressing .

### **Notice:**

*If a scale is verified printouts of immediate values are blocked.*

**Format frame:**

1	2	3	4 -12	13	14	15	16	17	18
stability	space	sign	mass	space	unit			CR	LF

<b>Stability character</b>	[space] if stable [?] if not stable [^] if an indication over the range [v] if fan indication below the range
<b>sign</b>	[space] for positive values or [-] for negative values
<b>mass</b>	9 characters justified to the right
<b>unit</b>	3 characters justified to the left
<b>command</b>	3 characters justified to the left

**Example 1:**

\_\_\_\_\_ **1 8 3 2 . 0 \_ g \_** CR LF – the printout generated from the scale after pressing ENTER/PRINT.

**Example 2:**

? \_ - \_\_\_\_\_ **2 . 2 3 7 \_ l b \_** CR LF - the printout generated from the scale after pressing ENTER/PRINT.

**Example 3:**

^ \_\_\_\_\_ **0 . 0 0 0 \_ k g \_** CR LF - the printout generated from the scale after pressing ENTER/PRINT.

**18.6. Continuous transmission**

The indicator can work in a continuous transmission mode. It can be switched on using RS232 commands (see 20.4).

**18.7. Configuring printouts**

**General information**

If some information included are redundant or not sufficient and there is a necessity of changes one can design their own protocol format in **EDYTOR WAG** computer program. This piece of software is accessible in: <http://www.radwag.com>

## 19. ERROR COMMANDS

- Err2** - Value beyond the zero range
- Err3** - Value beyond the tare range
- Err4** - Calibration mass or start mass beyond the acceptable range ( $\pm 1\%$  for weight,  $\pm 10$  for start mass)
- Err8** - Exceeded the time for tarring, zeroing, start mass adjustment or span adjustment
- NULL** - Zero value from the AD converter
- FULL2** - Measurement range overflow
- LH** - Start mass error, the mass on the weighing platform is beyond the acceptable range (-5% to +15% of start mass)

### Notice:

1. Errors: **Err2**, **Err3**, **Err4**, **Err8**, **null**, that appear on the display are also signalled by a short beep sound (about 1 sec.);
2. Error **FULL2** that appears on the display is also signalled by a continuous sound until the cause of error disappears.

## 20. TECHNICAL PARAMETERS

Scale type:	WPT/P 2	WPT/P 60
Max capacity	2kg	60kg
Min capacity	5g	100g
Reading accuracy	1g	20g
Verification scale interval	1g	20g
Range of tare	-2kg	-60kg
Pan size	230 x 160mm	400 x 500mm
Power supply	230V 50Hz/11V AC and 6xAA (NiMH)	
Temperature of work	0°C to +40°C	
Average operation when supplied from batteries	35 hours (average time)	
Display	LCD with backlight	
Net / Gross weight	3,5 / 4,8kg	15,5 / 17,8kg
Package dimensions	400 x 380 x 110mm	720 x 580 x 220mm

## 21. TROUBLE SHOOTING

Problem	Cause	Solution
Turning on does not work	Discharged batteries.	Connect to mains or change batteries
	No batteries (not installed or improperly installed)	Check the correctness of installation (polarization)
The scale turns off automatically	„t1” set to „YES” (Power save)	In „othr” submenu change „5.4 t1” to „no”
After turning on „LH” message on the display	Loaded weight pan during powering up	Unload the pan. Then the scale will indicator zero.

## 22. ADDITIONAL EQUIPMENT

### Accessories:

- KAFKA printer cable - **P0136**,
- Computer cable - **P0108**,
- EPSON printer cable - **P0151**,
- Power cord for car lighter 12V DC - **K0047**,
- Thermal printer - **KAFKA**,
- Dot matrix printer - **EPSON**,
- Additional display in plastic casing for PUE C/31- **WD- 4/1** (accessible with balance as complete set only),
- RS232 / RS485 converter for PUE C/31 – **KR-01**,
- RS232 / Ethernet converter for PUE C/31 - **KR-04**,

### Computer programs:

- “EDYTOR WAG” computer program,
- "RAD-KEY" computer program,
- "PW-WIN" computer program.

**MANUFACTURER**  
OF ELECTRONIC WEIGHING  
INSTRUMENTS



RADWAG WAGI ELEKTRONICZNE  
26 – 600 Radom, Bracka 28 Street  
POLAND  
Tel. +48 48 38 48 800, tel./fax. + 48 48 385 00 10  
Selling department + 48 48 366 80 06  
**[www.radwag.com](http://www.radwag.com)**

