

PUE C32

WEIGHING INDICATOR

USER MANUAL

ITKU-97-12-12-18-EN



RADWAG® RADWAG BALANCES AND SCALES
ADVANCED WEIGHING TECHNOLOGIES

DECEMBER 2018

CONTENTS

1. INTENDED USE	7
2. PRECAUTIONS	7
2.1. Operation	7
2.2. Battery Power Supply	8
3. MAINTENANCE ACTIVITIES	8
3.1. Cleaning ABS Components	8
3.2. Cleaning Stainless Steel Components	9
4. WARRANTY CONDITIONS	9
5. MECHANICAL DESIGN	10
5.1. Dimensions	10
5.2. Connectors Arrangement	10
5.3. RS232 Connectors	11
5.4. Inputs / Outputs	11
5.4.1. Technical Specifications	12
5.4.2. I/O Schematic Diagrams	12
6. UNPACKING AND INSTALLATION	12
7. START-UP AND OPERATION	13
7.1. Levelling	13
7.2. Connecting the Indicator to the Mains	13
7.3. Battery Status	13
8. OPERATION PANEL	14
9. HOME SCREEN	15
9.1. Top Bar	15
9.2. Weighing Result Window.....	16
9.3. Workspace	16
9.4. Pictograms	16
10. OPERATING THE MENU	17
10.1. Entering the Menu	17
10.2. Menu Keys	17
10.3. Entering Numeric and Text Characters and Signs.....	18
10.3.1. Numerical Box	18
10.3.2. Text Box	20
10.3.3. Diacritical Signs Table	21
10.3.4. Special Signs Table	22
10.4. Return to Weighing	22
11. PROGRAM	23
12. LOG IN OPERATION	23
12.1. Log in Procedure	23
12.2. Log out Procedure.....	23
12.3. Permission Levels	23
13. WEIGHING	24
13.1. Good Weighing Practice.....	24
13.2. Zeroing	25
13.3. Taring.....	25
13.4. Dual Range Devices.....	26
13.5. Weighing Unit Change	26
13.6. Setting MIN, MAX Thresholds	27
13.6.1. Setting MIN, MAX Threshold Using Programmable Button	28
13.6.2. Setting MIN, MAX Thresholds by Product Selection	28
13.6.3. Setting MIN, MAX Threshold Using Proximity Sensor	28
13.6.4. Setting MIN, MAX Threshold Using Digital Input	28
14. COMMUNICATION	29
14.1. RS232	29
14.2. Ethernet	29
14.3. Wireless Communication	29
14.4. USB A Port	31
14.5. USB B Port	31
15. PERIPHERAL DEVICES	34
15.1. Computer	34
15.1.1. Port.....	34
15.1.2. Address	35

15.1.3. Weighing Printout Template	35
15.1.4. Continuous Transmission	35
15.1.5. Printout Interval	35
15.1.6. E2R	36
15.2. Printer	36
15.2.1. Port.....	36
15.2.2. Code Page	37
15.2.3. Prefix, Suffix	38
15.2.4. Record of Measurement Data Onto a USB Flash Drive	38
15.3. Barcode Scanner	39
15.3.1. Port.....	39
15.3.2. Offset.....	39
15.3.3. Length of Code.....	40
15.3.4. Prefix, Suffix	40
15.3.5. Field Selection	40
15.3.6. Filtering	40
15.3.7. Test	41
15.4. Additional Display.....	41
15.4.1. Port.....	41
15.4.2. Bottom Text Area Template	42
16. PRINTOUTS	42
16.1. Print Mode: Header – GLP Printout - Footer.....	42
16.2. Non-Standard Printouts.....	44
16.3. Adjustment Report	45
16.4. Dosing Report	45
16.5. Formulation Report	46
17. INPUTS / OUTPUTS	47
17.1. Input Setup.....	47
17.2. Output Setup	47
18. DISPLAY.....	48
18.1. Workspace	49
18.1.1. Label	49
18.1.2. Text Box.....	50
18.1.3. Bar Graph.....	51
18.2. Keys.....	52
18.3. Default Screen Settings.....	54
19. PERMISSION LEVELS	55
19.1. Anonymous Operator	55
19.2. Date and Time.....	55
19.3. Printouts.....	55
19.4. Databases Edition.....	56
19.5. Select Database Record	56
20. UNITS	57
20.1. Units Availability.....	57
20.2. Start Unit.....	57
20.3. Gravitational Acceleration	57
20.4. Custom Units.....	58
21. MISCELLANEOUS PARAMETERS.....	58
21.1. Interface Language	58
21.2. 'Beep' Sound	59
21.3. Display Brightness	59
21.4. Proximity Sensors Sensitivity	59
21.5. Date and Time.....	59
21.6. Backlight Standby Time.....	60
21.7. Automatic Shutdown	60
21.8. Default Operator Settings	61
22. ADJUSTMENT.....	61
22.1. External Adjustment.....	61
22.2. User Adjustment.....	62
22.3. Start Mass Determination.....	62
22.4. Adjustment Report	62
23. SCALE DATA	63
24. WORKING MODES - GENERAL INFORMATION	63
24.1. Running Working Mode.....	63
24.2. Working Mode Accessibility.....	63

25. WORKING MODES - Local Settings	64
25.1. Readout	64
25.2. Proximity Sensors	65
25.3. Save Mode	65
25.4. Auto Threshold	66
25.5. Result Control	66
25.6. Autotare	67
25.7. Labelling Mode	67
25.7.1. Automatic C Label Triggering	67
25.8. Statistics	68
26. WORKING MODE – WEIGHING.....	69
26.1. Home Screen	69
26.2. Local Settings.....	69
27. WORKING MODE – PARTS COUNTING	70
27.1. Home Screen	70
27.2. Local Settings.....	70
27.2.1. Function of Automatic Correction of Reference Sample Mass	71
27.2.2. Minimum Reference Sample Mass	71
27.3. Setting Reference Sample Mass by Entering Mass of a Single Part.....	72
27.4. Setting Reference Sample Mass by Determining Mass of a Single Part.....	72
27.5. Setting Reference Sample Mass by Acquiring Mass of a Single Part from Database	73
27.6. Entering Reference Sample Mass to Weighing Device Memory.....	73
28. WORKING MODE - PERCENT WEIGHING.....	73
28.1. Home Screen	74
28.2. Local Settings.....	74
28.3. Reference Sample Mass Determined by Weighing	74
28.4. Reference Sample Mass Entered to the Weighing Device Memory.....	75
28.5. Setting Reference Sample Mass by Acquiring Mass of a Single Part from Database	75
29. WORKING MODE – DOSING.....	75
29.1. Home Screen	75
29.2. Local Settings.....	76
29.3. Automatic Dosing Procedure	77
29.4. Manual Dosing Procedure.....	80
29.5. Dosing Process Report	81
30. WORKING MODE – FORMULATIONS	82
30.1. Home Screen	82
30.2. Local Settings.....	82
30.3. New Formulation	83
30.4. Formulation Procedure	84
30.5. Formulation Report	86
31. DATABASES	87
31.1. Database Export	87
31.2. Database Import.....	88
31.3. Adding Database Record	88
31.4. Deleting Database Record	88
31.5. Deleting Database Content	89
31.6. Databases Edition	89
31.6.1. Operators	89
31.6.2. Products	89
31.6.3. Formulations.....	90
31.6.4. Packaging	91
31.6.5. Customers.....	91
31.6.6. Labels.....	91
31.6.7. Universal Variables.....	92
32. REPORTS.....	92
32.1. Export of Reports	92
32.2. Deleting Reports	93
32.3. Reports Preview.....	93
32.3.1. Weighings	93
32.3.2. Alibi	94
32.3.3. Dosing.....	94
32.3.4. Formulations.....	95
33. IMPORT / EXPORT	95
33.1. Data Export	96
33.2. Data Import	96

34. DIAGRAMS OF CONNECTION CABLES	97
35. TECHNICAL SPECIFICATIONS.....	98
36. ERROR MESSAGES	99
37. ANNEX 01 – Printout Variables	100
37.1. Variables List.....	100
37.2. Variables Formatting	102
38. ANNEX 02 – Label Template.....	104
38.1. Creation of Label Template via the Scale.....	104
38.2. Sending Label Template to Scale Memory.....	104
38.3. Assigning a Label with a Template to a Product.....	104
38.4. Assigning a C Label with a Template to a Product.....	105
38.5. Assigning a Label with a Template to a Customer.....	105
38.6. Printing a Label with a Template	105
39. ANNEX 03 - ZEBRA Printer Configuration.....	105
40. ANNEX 04 - Barcode Scanner Configuration	106

1. INTENDED USE

PUE C32 weighing indicator is a device intended to design industrial scales operating on the basis of load cells. The indicator features ABS plastic housing and 5" colour graphic display ensuring perfect readability. It is operated using 22-key membrane keypad equipped with programmable function keys.

Standard design offers two RS232 interfaces, USB type A, USB type B, Ethernet, wireless communication, 2 proximity sensors, 4 I/O. Optionally the indicator can be equipped with an internal battery, this allows its operation in places where there is no access to the mains. The device integrates with receipt and label printers, barcode scanners and PC accessories (mouse, keyboard, USB flash drive).



The PUE C32 indicator must not be operated in hazardous areas endangered with explosion of gases, and in dusty environments.



2. PRECAUTIONS

2.1. Operation

- A. Prior the first use, carefully read this user manual. Use the device only as intended.
- B. Place weighed loads in the centre of the weighing pan.
- C. Load the weighing pan with loads of gross weight which does not exceed the maximum capacity.
- D. Mind not to leave heavy loads on the weighing pan for longer periods of time.
- E. Protect the indicator against:
 - considerable temperature variation,
 - solar and UV radiation,
 - substances causing chemical reactions.
- F. The indicator is not intended to be operated in EX zones.
- G. In case of damage, immediately unplug the device from the mains.
- H. Indicators to be decommissioned must be decommissioned in accordance with valid legal regulations.

2.2. Battery Power Supply

PUE C32 indicator can optionally be supplied by NiMH battery (*nickel metal hydride*) of 1800 - 2800 mAh capacity.

	<i>Do not let battery discharge in case of prolonged storage of the device in low temperature.</i>
	<i>A worn out battery can be replaced only by the manufacturer or by the authorized service.</i>
	<i>The equipment including accumulators does not belong to regular household waste. The European legislation requires electric and electronic equipment to be collected and disposed separately from other communal waste with the aim of being recycled. Dear user, you are obliged to dispose of the worn out battery as regulated.</i>

Notice: Symbols on batteries identify harmful compounds: Pb = lead, Cd = cadmium, Hg = mercury.

3. MAINTENANCE ACTIVITIES

In order to ensure safety in the course of cleaning, it is necessary to disconnect the device from the mains. With this condition met, uninstall the weighing pan and other detachable scale components.

	<i>Cleaning the weighing pan while still installed may cause damage of the measuring system.</i>
--	---

3.1. Cleaning ABS Components

To clean dry surfaces and avoid smudging, use clean non-colouring cloths made of cellulose or cotton. You can use a solution of water and detergent (soap, dishwashing detergent, glass cleaner). Gently rub the cleaned surface and let it dry. Repeat the cleaning process if needed.

In case of hard to remove contamination, e.g: residues of adhesive, rubber, resin, polyurethane foam etc., you can use a special cleaning agents based on a mixture of aliphatic hydrocarbons that do not dissolve plastics. Before using the cleanser for all surfaces we recommend carrying out tests. Do not use products containing abrasive substances.

3.2. Cleaning Stainless Steel Components

Avoid using cleansers containing any corrosive chemicals, e.g. bleach (including chlorine). Do not use products containing abrasive substances. Always remove the dirt using microfiber cloth to avoid damage of protective coating.

In case of a daily maintenance:

1. Remove the dirt using cloth dipped in warm water.
2. For best results, add a little dishwashing detergent.

4. WARRANTY CONDITIONS

- A. RADWAG feels obliged to repair or exchange all elements that appear to be faulty by production or by construction.
- B. Defining defects of unclear origin and means of their elimination can only be realized with assistance of manufacturer and user representatives.
- C. RADWAG does not bear any responsibility for damage or losses resulting from unauthorized or inadequate performing of production or service processes.
- D. The warranty does not cover:
 - mechanical damage caused by product exploitation other than intended, damage of thermal and chemical origin, damage caused by lightning, overvoltage in the power network or other random event,
 - inappropriate cleaning habits.
- E. Loss of warranty takes place if:
 - a repair is carried out outside RADWAG authorized service point,
 - service claims intrusion into mechanical or electronic construction by unauthorized people,
 - the indicator does not bear security seal stickers.
- F. Warranty conditions outline the warranty period for rechargeable batteries attached to the device for 12 months.
- G. For detailed warranty conditions read the warranty certificate.
- H. Contact with the central authorized service: +48 48 384 88 00 ext. 106 and 107.

5. MECHANICAL DESIGN

5.1. Dimensions

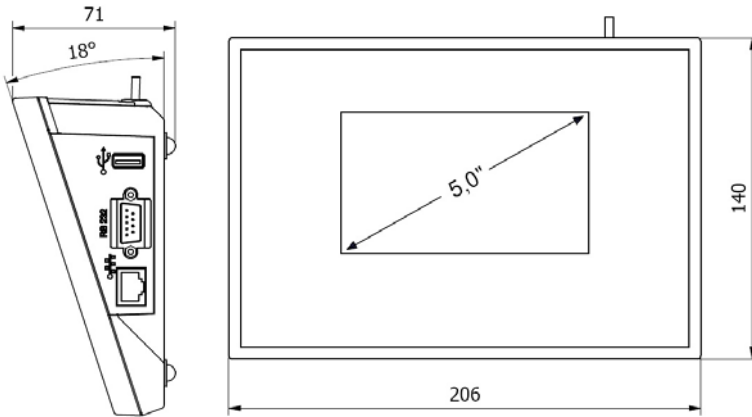

PUE C32 overall dimensions

5.2. Connectors Arrangement

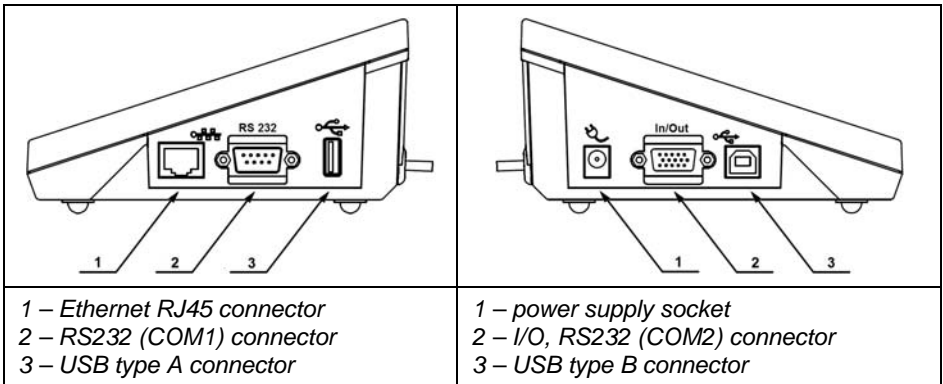

5.3. RS232 Connectors

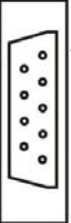
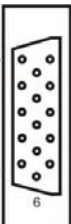
	<p>RS232 - DB9/M connector (male), front:</p> <p>Pin2 - RxD Pin3 – TxD Pin4 - 5VDC Pin5 – GND</p>
	<p>RS232 - DSUB15/F connector (female), front:</p> <p>Pin8 - TxD2 Pin9 - 5VDC Pin10 - GND Pin13 - RxD2</p>

5.4. Inputs / Outputs

Standard PUE C32 indicator is equipped with 4 optoisolated inputs and 4 semiconductor outputs (solid-state relays). The signals are fed through DSUB15/F connector.

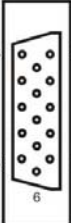
	<p>I/O, RS232 DSUB15/F (female) connector, front:</p> <p>Pin1 – GNDWE Pin2 - OUT1 Pin3 - OUT2 Pin4 – COMM Pin6 - IN4 Pin7 - IN3 Pin11 - IN2 Pin12 - IN1 Pin14 - OUT4 Pin15 - OUT3</p>
--	---

5.4.1. Technical Specifications

Output parameters	
Outputs quantity	4
Outputs type	Solid-state relay
Cable cross-section	0.14 - 0.5mm ²
Maximum switching current	0.5A DC
Maximum voltage	30VDC

Input parameters	
Inputs quantity	4
Inputs type	Optoisolated
Cable cross-section	0.14 - 0.5mm ²
Voltage range	5÷24VDC

5.4.2. I/O Schematic Diagrams

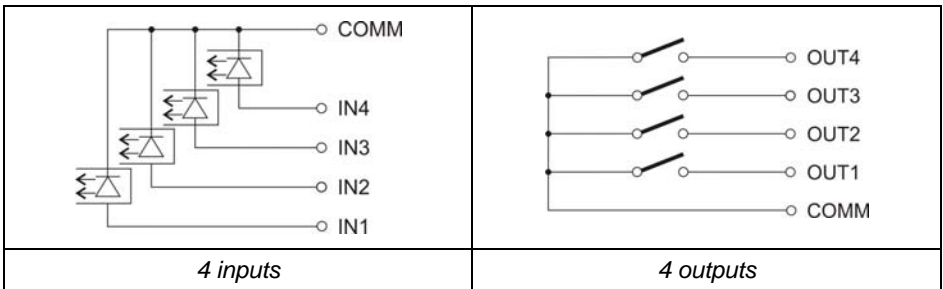

6. UNPACKING AND INSTALLATION

- A. Take the indicator out of the packaging.
- B. Connect the indicator to a weighing platform, next place the weighing device on a flat and even surface. Keep it far away from any sources of heat.

7. START-UP AND OPERATION

7.1. Levelling

To level the weighing instrument turn its feet. Keep turning the feet until the air bubble takes central position:



7.2. Connecting the Indicator to the Mains







The weighing device can be connected to the mains only with a power supply that comes standard with a particular model. Nominal voltage of the power supply (specified on the power supply data plate) has to be compatible with the mains nominal voltage.

Procedure:

- Connect the power supply to the mains. Plug it to the power supply socket that is located on the indicator's left side.
- Press  key, it is to be found on the top of the operation panel.
- Upon completed start-up the home screen is displayed automatically.

7.3. Battery Status

Optional indicator design features an internal battery.  pictogram, displayed at the top of the screen, either signals battery status or informs that battery charging process is in progress:

-  pictogram displayed in a cyclic manner: battery charging.
-  pictogram displayed continuously: battery charged within 75% - 100% range of permissible voltage.
-  pictogram displayed continuously: battery charged within 50% - 75% range of permissible voltage.
-  pictogram displayed continuously: battery charged within 25% - 50% range of permissible voltage.
-  pictogram displayed continuously: battery discharged (charge status below 25% of the permissible voltage), connect the scale to the mains in order to charge it.
- Blinking  pictogram: damaged battery or battery lack.
- No  pictogram: scale not equipped with the battery.







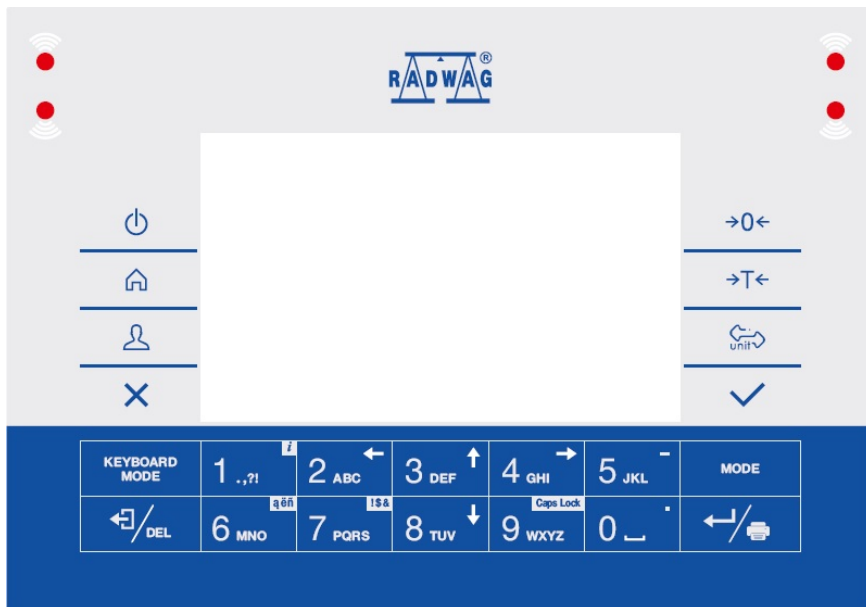



Battery discharge is signalled by the following message: <Excessively discharged battery. Scale shutdown is to occur>. Upon scale shutdown, connect it to the mains in order to charge its battery.

8. OPERATION PANEL



Keys:

	Press to switch the indicator on / off.
	Press to enter the main menu.
	Press to log in.
	Press to cancel the message.
	Press to zero the scale.
	Press to tare the scale.
	Press to change the weighing unit.

	Press to confirm the message.
	Press to confirm the weighing result (PRINT). Press to confirm the messages (ENTER).
	Press to cancel the messages.
	Press to change the working mode.
	Programmable key assigned to a screen button. i key – press it for a longer period of time to get scale info.
	Programmable key assigned to a screen button.
	Programmable key assigned to a screen button.
	Programmable key assigned to a screen button.
	Programmable key assigned to a screen button.

9. HOME SCREEN

The home screen features 4 sections: top bar, weighing result window, workspace, pictograms.







Home screen view:



9.1. Top Bar



The top bar displays the following information:

 Weighing	Working mode name and symbol.
PUE C32	Weighing device name.
	Symbol informing that wireless communication is on.
	Symbol informing that communication with a USB flash drive is on.
	Symbol informing that PC keyboard is connected.
	Symbol informing that printer is connected.
	Battery charge status.
	Symbol informing that communication with a PC computer is on.
E2R	Symbol informing that communication with E2R SYSTEM is on.

9.2. Weighing Result Window

Weighing result window provides all weighing related data.



9.3. Workspace

The workspace is to be found underneath the weighing result window.

Product:	Tare: 0.000 kg
User:	Sum: 0.000 kg

The workspace comprises 4 programmable widgets. Each working mode features default home screen widgets set. You can customize the screen. For detailed information concerning the workspace read section 'Display'.

9.4. Pictograms

The pictograms assigned to operation panel keys are to be found underneath the workspace.

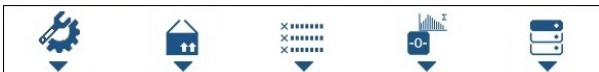

You can define on-screen pictograms individually for each working mode. For detailed procedure informing you how to define on-screen pictograms read section 'Display'.

10. OPERATING THE MENU

In order to navigate the program menu use the operation panel.



10.1. Entering the Menu

In order to enter the menu press  key. Background colour of the first menu entry differs from the remaining ones. To navigate the program menu use the keys that operate as arrow keys.

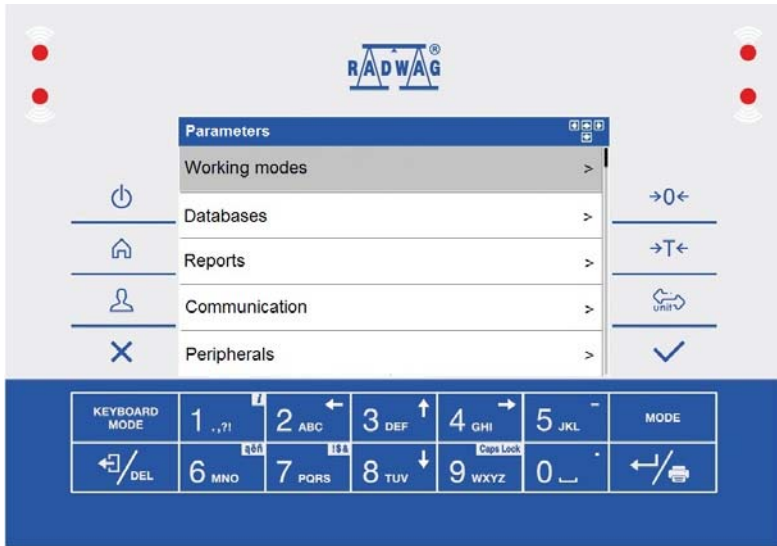
Menu view



10.2. Menu Keys

	Press to enter the main menu. Press to go to the home screen.
	Press to move one menu level up, or to discard entering parameter modifications.
	Press to move one menu level up. Press to delete a character when editing numeric and text values.

KEYBOARD MODE	Press to change keyboard mode when editing numeric and text values.
MODE	Press to select/change working mode.
	Press to confirm/accept modifications.
2 ABC ←	Press to move one menu level up, or to discard entering parameter modifications.
3 DEF ↑	Press to select higher-level parameters group, or to edit parameter value and change it by one digit up.
4 GHI →	Press to select parameters group that you want to operate. The first parameter of the selected parameters group is displayed.
8 TUV ↓	Press to select lower-level parameters group, or to edit parameter value and change it by one digit down.

10.3. Entering Numeric and Text Characters and Signs

Depending on a type of data entered to indicator's memory the software offers two different edit boxes:





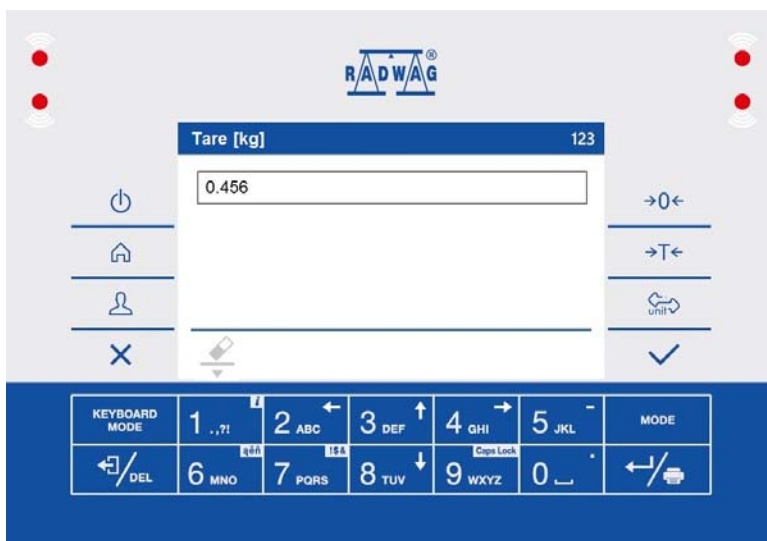

- numerical box (for entering part mass values, tare values, etc.).
- text box (for entering printout template, universal variable value, etc.).

Button functions change depending on the edit box type.











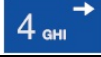

10.3.1. Numerical Box



Where:

	Digits mode. To change keyboard working mode press  key. Keyboard working mode options:  - digits mode,  - arrow keys operation,  - bottom bar operation.
	Press to clear box content.







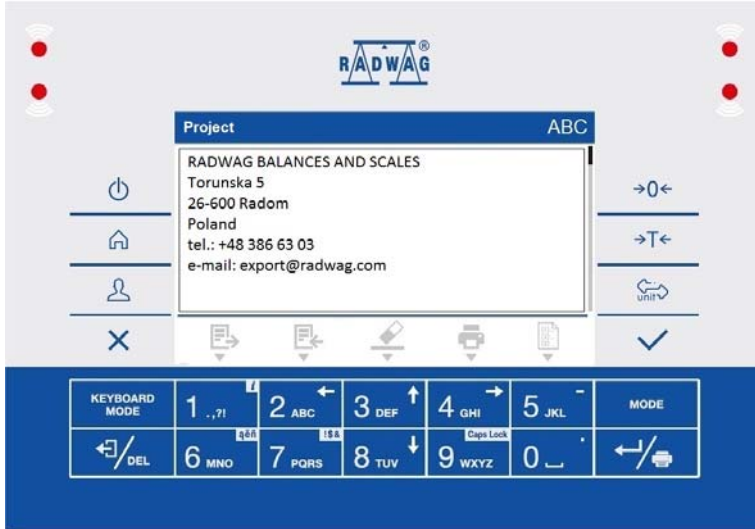





Keys:

	Press to enter digit 1.
	Press to enter digit 2.
	Press to enter digit 3.
	Press to enter digit 4.
	Press to enter digit 5. Press to enter „-“ (minus) sign, hold the key for a few seconds.
	Press to enter digit 6.
	Press to enter digit 7.
	Press to enter digit 8.
	Press to enter digit 9.
	Press to enter digit 0. Press to enter „.” sign (dot), hold the key for a few seconds. (dot) sign.
	Press to delete one character.
	Press to exit, the box remains unmodified.
	Press to confirm the modifications.
	Press to change keyboard working mode.

10.3.2. Text Box



Where:

	<p>Capital letters mode. To change keyboard working mode press  key. Keyboard working mode options:  - upper-case characters mode,  - lower-case characters mode,  - digits mode,  - arrow keys operation,  - bottom bar operation.</p>
	<p>Press to save project to *.lb file on USB flash drive.</p>
	<p>Press to read project saved to *.lb file on USB flash drive.</p>
	<p>Press to clear box content.</p>
	<p>Press to print project using printer connected to the indicator.</p>
	<p>Press to view list of variables that can be used in the project.</p>

Keys:



	Press to enter . , { } : ° - .
	Press to enter a b c . Press to move the cursor to the left, hold the key for a few seconds.
	Press to enter d e f . Press to move the cursor up, hold the key for a few seconds.
	Press to enter g h i . Press to move the cursor to the right, hold the key for a few seconds.
	Press to enter j k l . Press to enter „ - ” sign, hold the key for a few seconds.
	Press to enter m n o . Press to activate „ ąęñ ” function (diacritical signs table).
	Press to enter p q r s . Press to activate „ !\$& ” function (special signs table).
	Press to enter t u v . Press to move the cursor down, hold the key for a few seconds.
	Press to enter w x y z . Press to activate „ Caps Lock ” function.
	Press to enter ␣ (space) sign. Press to enter „.” sign (dot), hold the key for a few seconds. ”.
	Press to go to the next line in the editing box.
	Press to delete one character.
	Press to exit, the box remains unmodified.
	Press to confirm the modifications.
	Press to change keyboard working mode.

10.3.3. Diacritical Signs Table

In order to activate diacritical signs table while editing text box it is necessary to press and hold key. Diacritical signs characteristic for a particular interface language are automatically added to the table when the given language gets selected.

Diacritical signs table: Polish.	Diacritical signs table: English, German, French, Spanish.
ą ć ę ł ń ó ś ź ż á č	ä ö ü à â æ œ ç è é ê
đ é ě í ñ ř š ú û ý ž	ë î ï ô ù û ü ÿ ñ á ã
â ă ă ĩ î đ ǒ ǒ ǒ ǒ ǒ ǒ	à ì í î ï ò ó õ ô ú ý þ š
↑ !\$& ũ ũ ł ł ą ø æ	↑ !\$& ž ğ ş ø ı ß

Where:



	Press to activate „Caps Lock” function.
	Press to switch to special signs keyboard.

10.3.4. Special Signs Table

In order to activate special signs table while editing text box it is necessary to press and hold  key.



,	.	?	'	!	"	-	()	@	/
:	_	;	+	&	%	*	=	<	>	£
€	§	¥	°	[]	{	}	\	~	^
↑	ąęñ	#	\$		μ	ß	©	®	™	`

Where:

	Function inactive.
	Press to switch to diacritical signs keyboard.

10.4. Return to Weighing

Introduced modifications are automatically recorded upon return to the home screen. To return to the home screen:

- press  key repeatedly, keep pressing the key until you see the home screen,
- press  key, the home screen is displayed immediately.

11. PROGRAM

Program menu is divided into function groups. Function group is a group of interrelated parameters.



Function Groups: Working modes, Databases, Reports, Communication, Peripherals, Printouts, Inputs / Outputs, Display, Permissions, Units, Adjustment, Misc, Scale data.

12. LOG IN OPERATION

In order to access operator-related parameters and to edit databases, you need to log in as an operator with **<Administrator>** permission level.

	<p><i><Admin> is a default operator set on each brand new indicator. The default operator is assigned with <Administrator> permission level. <Admin> account is not protected by password. Logging of default operator is carried out automatically upon indicator start-up. In case of modification of default operator data or upon adding new operators, it is necessary to log in manually.</i></p>
---	--

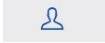
12.1. Log in Procedure

- Go to the home screen, press  key, wait for the operators database to open.
- Select particular operator, wait for the on-screen keyboard with a password box to open.
- Enter the password and press  key to confirm, the home screen is displayed.

12.2. Log out Procedure

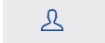
- Go to the home screen, press  key, wait for the operators database to open.
- Select **<Log out>** option, the home screen is displayed.

12.3. Permission Levels



There are 4 permission levels: Administrator, Advanced Operator, Operator, None.

Access to operator-related parameters and program functions is conditioned by a permission level:

Permission levels	Available parameters and functions
None	Permission to edit operator-related parameters not granted. Operator can neither accept the weighing result nor start the following operations: entering reference sample mass and determining reference sample quantity in <Parts counting> mode, entering reference sample mass and determining reference sample in <Percent weighing> mode, dosing, making formulations.
Operator	Operator can edit <Readout>, <Misc> parameter groups (operation of <Date and time> parameter and <Restore operator's default settings> function excluded). Operator can run and carry out all weighing operations.
Advanced operator	Operator can edit all operator-related parameters excluding <Date and time> parameter. Operator can run and carry out all weighing operations.
Administrator	Operator can edit all operator-related parameters and all databases, and use all functions. Operator can run and carry out all weighing operations.

13. WEIGHING

Load the weighing pan. Read the result when  stability marker is displayed.

	Only stable weighing results can be recorded (stability marker ) ,
---	--

13.1. Good Weighing Practice

In order to assure a long-term device operation, wherein correct measurements are provided, the following principles must be adhered to:

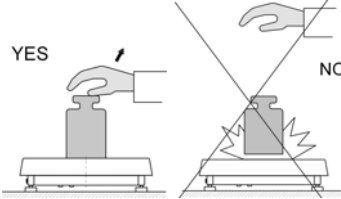
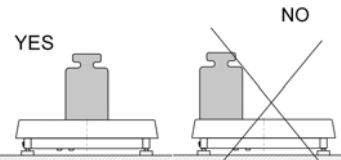

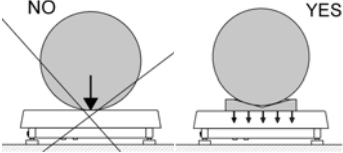
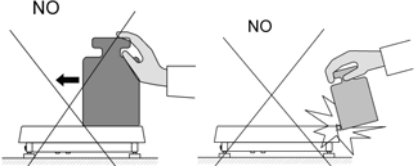
<p>Avoid applying mechanical shocks to the weighing pan.</p>	
<p>Place the loads centrally on the weighing pan (refer to section 3.6.2 of EN 45501 standard concerning eccentric loading).</p>	

<p>Do not apply concentrated forces (total load in one point).</p>	
<p>Avoid side loading, in particular side shocks.</p>	



13.2. Zeroing

To zero mass indication press  key. Zero indication and the following pictograms are displayed:  and .

Zeroing operation means determining new zero point, recognized by the weighing device as precise zero. The instrument can be zeroed only when the indication is stable.





	<p>Indication can be zeroed only within $\pm 2\%$ range of maximum capacity. If the zeroed value is greater than $\pm 2\%$ of the maximum capacity, then the software displays a respective error message:</p> <div data-bbox="340 948 890 1054" style="border: 1px solid black; padding: 10px; margin: 10px auto; width: fit-content;">  <p style="text-align: center;">Zeroing out of range Press taring button or restart the balance</p> </div>
---	--

13.3. Taring

To determine net weight value, load the weighing pan with a packaging, wait for a stable indication and press  key. Zero indication and the following pictograms are displayed:  and . The weighing device has been tared.

Remember not to exceed scale's maximum capacity, i.e. sum of tare weight value and load weight value must be lower than the maximum capacity value. Upon unloading the weighing pan, the sum of tared masses with minus sign is displayed.

You can assign tare value to a particular product stored in the database. In such case the assigned tare value is automatically acquired upon selection of the given product.



	<p><i>It is impossible to tare zero or negative values. When you tare zero or negative values the indicator responds with the following message:</i></p>		
<table border="1"><tr><td data-bbox="365 357 427 414"></td><td data-bbox="450 360 846 408"><p>Tarring out of range Press zeroing button or restart the balance</p></td></tr></table>			<p>Tarring out of range Press zeroing button or restart the balance</p>
	<p>Tarring out of range Press zeroing button or restart the balance</p>		

13.4. Dual Range Devices

N/A in case of single range scales

Switching from weighing with the accuracy of the **I weighing range** to weighing with the accuracy of the **II weighing range** takes place automatically upon exceeding Max of the **I weighing range**.

In case of dual range scales:

- upon switching to weighing with the accuracy of the I weighing range,  pictogram/marker is displayed on the left,
- upon switching to weighing with the accuracy of the II weighing range,  pictogram/marker is displayed on the left.

Switching from weighing with the accuracy of the **II weighing range** to weighing with the accuracy of the **I weighing range** takes place automatically upon unloading the weighing pan and returning to AUTOZERO – ( pictogram/marker is displayed).

13.5. Weighing Unit Change

You can change the weighing unit, to do it press  key.

Options in case when the main unit is [g]:

- g (gram),
- kg (kilogram),
- ct (carat),
- lb (pound)*,
- oz (ounce)*,
- N (newton)*,

- u1 (custom unit 1)*,
- u2 (custom unit 2)*.

*) – unit disabled for verified weighing devices.

Options in case when the main unit is [kg]:

- kg (kilogram),
- lb (pound)*,
- N (newton)*,
- u1 (custom unit 1)*,
- u2 (custom unit 2)*.

*) – unit disabled for verified weighing devices.

	<p><i>You can declare start unit and two custom units – for detailed information read section 20, „UNITS”.</i></p>
---	---

13.6. Setting MIN, MAX Thresholds

MIN, MAX thresholds are used:



- to control mass of the weighed loads (read section 25.5 of this user manual),
- for graphic visualization informing you how much of the weighing device capacity is used (read section 18.1.3 of this user manual),
- to control the external automation systems using digital outputs of the indicator (read section 17.2 of this user manual).

The mass is considered to be correct if it is comprised within MIN and MAX threshold values. You can set MIN, MAX thresholds as follows:

- using programmable  **Set MIN, MAX** button,
- selecting product with set thresholds,
- using a proximity sensor,
- using a digital input.

	<p><i>MAX threshold value has to be greater than MIN threshold value.</i></p>
---	--



13.6.1. Setting MIN, MAX Threshold Using Programmable Button

- Enter **<Display / Buttons functions>** submenu.
- Edit a given button.
- Select **<Set MIN and MAX>** parameter from the list.
- Exit to the home screen.
- Press previously programmed button, **<Min>** numerical box is opened.
- Enter respective value and press  key to confirm changes, **<Max>** numerical box is opened.
- Enter respective value and press  key to confirm changes.



13.6.2. Setting MIN, MAX Thresholds by Product Selection

- Enter **<Databases / Products>** submenu.
- Edit a given product and enter respective threshold values.
- Exit to the home screen and press  button to select product with set thresholds.

13.6.3. Setting MIN, MAX Threshold Using Proximity Sensor

- Enter **<Working modes>** menu and select respective working mode.
- Edit a given proximity sensor (left or right).
- Select **<Set MIN and MAX>** parameter from the list.
- Exit to the home screen.
- Move your hand near the previously programmed proximity sensor, **<Min>** numerical box is opened.
- Enter respective value and press  key to confirm changes, **<Max>** numerical box is opened.
- Enter respective value and press  key to confirm changes.

13.6.4. Setting MIN, MAX Threshold Using Digital Input

- Enter **<Inputs / Outputs>** menu, next enter **<Inputs>** submenu.
- Edit a given input.
- Select **<Set MIN and MAX>** parameter from the list.
- Exit to the home screen.
- Activate the previously set input signal, **<Min>** numerical box is opened.
- Enter respective value and press  key to confirm changes, **<Max>** numerical box is opened.
- Enter respective value and press  key to confirm changes.

14. COMMUNICATION

The indicator can communicate with peripheral devices, the communication is established via the following ports: RS232 (1), RS232 (2), USB A, USB B, Ethernet, Wireless communication.

To set the ports go to <  / **Communication**> submenu.

14.1. RS232



- Select <**RS232 (1)**> or <**RS232 (2)**> port.
- Set transmission parameters:

Baud rate	2400, 4800, 9600, 19200, 38400, 57600, 115200 bit/s.
Parity	None, Odd, Even.

14.2. Ethernet





- Select <**Ethernet**> port.
- Set transmission parameters:



DHCP	<input checked="" type="checkbox"/> Yes, <input type="checkbox"/> No
IP Address	0.0.0.0
Subnet mask	0.0.0.0
Default gateway	0.0.0.0
MAC address	---

	<i>Set the transmission parameters in accordance with your local network.</i>
	<i><MAC address> parameter is automatically assigned to the weighing device with <Read-only> attribute.</i>
	<i>If you select <input checked="" type="checkbox"/> option for <DHCP> parameter, the remaining transmission parameters are given <Read-only> attribute.</i>

14.3. Wireless Communication



Indicators equipped with wireless communication module, display  pictogram at the top of the screen, provided that the module is active. The pictogram indicates the following connection statuses:

No.	Pictogram	Description
1		The weighing device is connected, very strong signal.
2		The weighing device is connected, strong signal.
3		The weighing device is connected, poor signal.
4		The weighing device is connected, very poor signal.
5		No connection (signal too poor, selected network unavailable, connection parameters invalid – password, IP etc.).

	<i>Set the transmission parameters in accordance with your local network.</i>
	<i>In order to provide correct communication between the computer and the weighing device via <Wireless communication> port, you must set computer port parameter in your scale to <Wireless communication> value. You must also set wireless communication parameters, to do it correctly follow the below procedure.</i>

Procedure:

- Enter **<Activation>** parameter and activate wireless communication.
- Enter **<Network configuration>** submenu and set respective values:

Networks scanning	Enter this parameter to trigger automatic search for available networks.
DHCP	 - select this option to make the program automatically read and display data assigned by a Router to which the weighing device is to be connected.  - select this option to enter manually data such as: <IP Address>; <Subnet mask>; <Default gateway>.
IP Address	Enter this parameter to set weighing device IP address.
Subnet mask	Enter this parameter to set subnet mask.
Default gateway	Enter this parameter to set default gateway.

- When you run **<Networks scanning>** function, the scanning starts and message **"Networks scanning. Please wait..."** is displayed, next you see a list of networks detected by the weighing device along with signal strength and network channel number.
- Select the network you want and enter the access password (if required).
- **<Wireless communication>** submenu is displayed, connection procedure runs automatically.
- When the communication gets established, **<Connected>** status is displayed.

- If you are waiting too long for the communication to be established it means that incorrect parameters must have been entered (e.g. password). Check the settings and try to establish communication again.
- If you fail to establish the communication, contact RADWAG service team.

The selected network and settings of parameters for connection are stored in scale memory. The scale connects to the network in accordance with these settings each time it is switched on. To disconnect the network go to **<Activation>** parameter.

14.4. USB A Port

USB port of type A is intended for:

- connecting a USB flash drive in order to enable:
 - printout of measurement data (set <Printer/Port> parameter to <Pendrive> value),
 - databases export/import,
 - operator's parameters export/import,
 - Alibi and weighing reports export,
- connecting scale to PCL printer,
- connecting EPSON TM-T20 printer (featuring USB port).

	<p><i>The USB flash drive must support FAT files system.</i></p>
---	---

14.5. USB B Port

USB port of type B is intended for connecting the scale to a computer. In order to make connection of scale and computer possible, it is necessary to install virtual COM port in a computer. To carry out this procedure, you need a respective driver installer which may be either downloaded from www.radwag.pl website or taken from a CD with manuals: **RADWAG USB DRIVER x.x.x.exe**.

Steps:

1. Run the driver installer and follow the commands.

	<p>Select language version and press „OK” button to confirm.</p>
---	--



In order to continue press „Next” button.

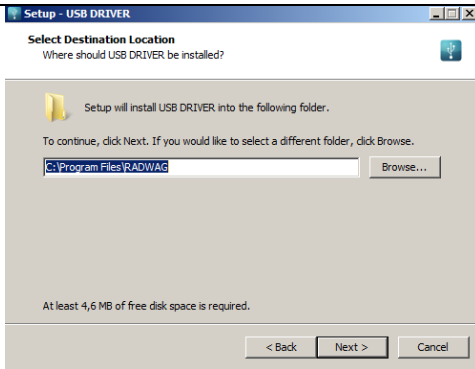

Select directory and press „Next” button.

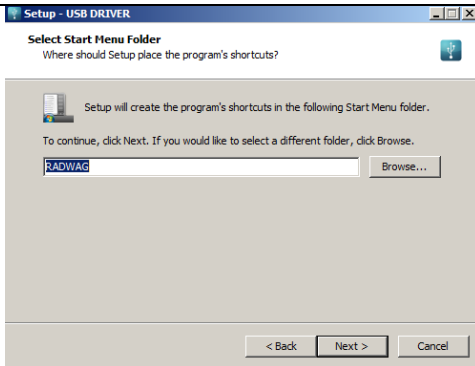

In order to start installation process, press „Next” button.

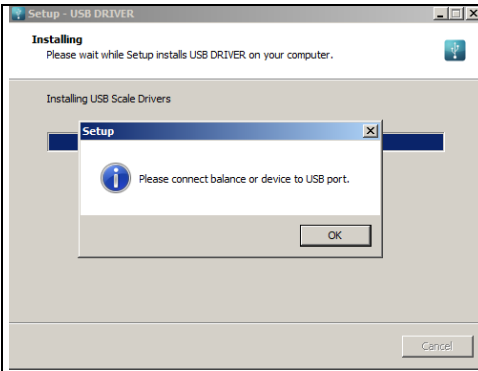

Connect the scale to a computer, use 1.8-meter long USB A/B cable maximum (in case of an already connected scale, it is necessary to disconnect it and reconnect using USB cable). Respective message box is displayed, press **OK** button to confirm.



Press „**Finish**” button.

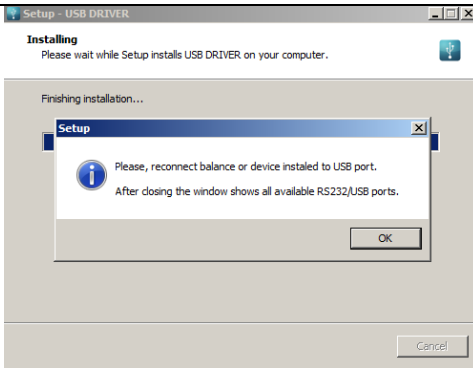

Connect the scale to a computer again, use 1.8-meter long USB A/B cable maximum. Respective message box is displayed, press **OK** button to confirm. Respective message box is displayed, press **OK** button to confirm.

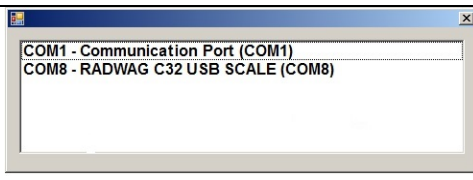



„**COM ports Screen**” automatically displays number of installed COM port. In this very case it is COM8.

2. Enter **<Peripherals / Computer / Port>** submenu and set **USB B** option.
3. Run program for measurements readout.
4. Set communication parameters – select COM port that was installed in the course of drivers installation (in this very case it is COM8).
5. Connection between the scale and a computer is established.

15. PERIPHERAL DEVICES

15.1. Computer

The weighing device can connect with a computer. Active **weighing device – computer** connection is signalled by  pictogram (top bar of the home screen). To configure 'scale' - 'computer' connection settings go to **<  / Peripherals / Computer>** submenu.

15.1.1. Port

Parameter allowing you to set port for communication between the weighing device and the computer. Available ports:

RS232 (1)	RS232 port (DB9/M connector).
RS232 (2)	RS232 port (DSUB15/F connector).
USB B	USB port of type B.
Ethernet	Ethernet port (RJ45 connector).
Wireless communication	Port for sending data to a computer via wireless network.

Procedure:

- Enter **<Peripherals / Computer / Port>** submenu and select respective port, **<Port settings>** submenu differs depending on the selected port:

Port	Settings
RS232 (1)	Baud rate: 2400 - 115200 bit/s. Parity: None, Odd, Even.
RS232 (2)	
USB B	-
Ethernet	IP Address: IP address of the scale. Port: number of port for transmission protocol. Timeout [ms]: time delay - time interval for disconnection, counted from the moment of the most recent command sent from the peripheral device to which the weighing device is connected.
Wireless communication	

15.1.2. Address

Parameter allowing you to set address of scale connected with the computer.

Procedure:

- Enter **<Peripherals / Computer / Address>** submenu, **<Address>** edit box is displayed.
- Enter the address and press  key to confirm changes.

15.1.3. Weighing Printout Template

Template of an individual printout designed using scale and sent to a computer.

Procedure:

- Enter **<Peripherals / Computer / Weighing printout template>** submenu, **<Weighing printout template>** edit box is displayed.
- Modify the template and press  key to confirm changes.



15.1.4. Continuous Transmission

Parameter allowing you to activate 'scale' - 'computer' continuous transmission. In order to send the content of **<Weighing printout template>** to a computer continuously you must activate **<Continuous transmission>** parameter.

Procedure:

- Enter **<Peripherals / Computer / Continuous transmission>** submenu and set respective value.

Options:

	Continuous transmission disabled.
	Continuous transmission enabled.

15.1.5. Printout Interval

Parameter allowing you to set frequency of print of **<Weighing printout template>** when continuous transmission is activated. Interval for printouts is set in seconds with 0.1 [s] accuracy within 0.1 - 1 000 [s] range.

Procedure:

- Enter **<Peripherals / Computer / Interval>** submenu, **<Interval>** edit box is displayed.

- Enter respective value and press  key to confirm changes.

15.1.6. E2R



Parameter allowing you to establish connection between the scale and the **E2R System** PC software. **E2R System** is a modular solution designed to comprehensively manage production processes, some stages of which consist in weighing.

	<E2R> can be activated exclusively by an <Administrator> user. In case of integration of the scale with <E2R System> software, editing of databases on scales is disabled.
---	---

Procedure:

- Enter **<Peripherals / Computer / E2R>** submenu and set respective option.

Options:

	Connection with E2R System inactive.
	Connection with E2R System active.

15.2. Printer

<Printer> submenu allows you to:

- set port for establishing communication with printer,
- select printer code page,
- define print start - **<Prefix>** parameter,
- define print end - **<Suffix>** parameter.

To set scale-printer communication parameters go to **<**  **/ Peripherals / Printer>** submenu.

15.2.1. Port

Parameter allowing you to set port for communication between the weighing device and the printer. Available ports:

RS232 (1)	RS232 port (DB9/M connector).
RS232 (2)	RS232 port (DSUB15/F connector).
USB A	USB port of type A.
USB B	USB port of type B. used for connecting a computer with RADWAG-designed program, e.g. RAD KEY.

Ethernet	Ethernet port (RJ45 connector). used for connecting a network printer or a computer with RADWAG-designed program, e.g. RAD KEY.
Pendrive	USB port of type A. used for connecting a USB flash drive in order to print weighings to a text file.
Wireless communication	Port for sending data to a computer or a network printer via a wireless network.

Procedure:

- Enter **<Peripherals / Printer / Port>** submenu and set respective option. **<Port settings>** submenu differs depending on the selected port:

Port	Settings
RS232 (1)	Baud rate: 2400 - 115200 bit/s. Data bits: 7, 8. Stop bits: 1, 2. Parity: None, Odd, Even.
RS232 (2)	
USB A	-
Pendrive	-
USB B	-
Ethernet	IP Address: IP address of the scale. Port: number of port for transmission protocol. Timeout [ms]: time delay - time interval for disconnection, counted from the moment of the most recent command sent from the peripheral device to which the weighing device is connected.
Wireless communication	

15.2.2. Code Page

In order to provide correct integration of the weighing device with the printer (correct printout of diacritical signs of a given language) it is necessary to make sure that the code page of a sent printout is accordant with a code page of a printer. There are two methods for obtaining code page accordance:

- by setting the right code page in the settings of a printer (read the user manual of the printer) – it must be accordant with the printout code page of a weighing device:

Code page	Language
1250	Polish, Czech, Hungarian.
1252	English, German, French, Spanish, Italian.
1254	Turkish.

- by sending the control code from the weighing device, which automatically sets the right code page of the printer (i.e. code page accordant with the one of a weighing device).



Default code page value of the printer is 1250 – Central European code page.

Exemplary weighing device settings for correct printout of Polish signs with use of EPSON printer connected to RS232 port:

	EPSON TM-U220D	EPSON TM-T20	EPSON TM-T20
Baud rate	9600 bit/s	38400 bit/s	38400 bit/s
Parity	None	None	None
Code page	852	1250	852
Prefix	-	1B742D	1B7412

15.2.3. Prefix, Suffix

Prefix and suffix are controlling codes (given in a hexadecimal format) sent to a printer at print start - **<Prefix>** parameter, and at print end - **<Suffix>** parameter. Sending these codes allows to control globally information and actions carried out at the beginning and/or at the end of each printout sent from a weighing device to a printer. Most frequent usage:

- **Prefix** - sending info on print code page.
- **Suffix** - sending paper crop command in EPSON printers (in case of printer equipped with an auto-cutter blade). *Paper crop in EPSON printer – code 1D564108.*

Settings of **<Prefix>** and **<Suffix>** parameters are valid for all printouts sent via the weighing device, e.g.: calibration reports, statistics and header, footer and GLP printouts.

15.2.4. Record of Measurement Data Onto a USB Flash Drive

Scale program enables record of measurement data onto an external flash drive.

Procedure:

- Plug a USB flash drive into **USB type A** port.
- Enter **<Peripherals / Printer / Port>** submenu and set **<Pendrive>** value. Return to weighing.
- Now the measurement data is saved to a text file on a USB flash drive whenever you press  key. The file is generated automatically by a scale software under **printout.txt** name.



Remove the USB flash drive from a weighing device USB port after about 10s counting from the last measurement record, only after this time the data is saved. Next plug the USB flash drive to a computer and read the saved text file.

New data is recorded to an existing file therefore it is possible to continue recording measurement data to the file once created.



USB flash drive must comprise <FAT files system>.

15.3. Barcode Scanner

The scale can integrate with a barcode scanner. The barcode scanner is used to facilitate quick search for database records.



Enter <Communication> submenu and set baud rate for a barcode scanner (by default 9600b/s). For detailed description of 'scale' - 'barcode scanner' communication read ANNEX 04 of this user manual.

15.3.1. Port

Communication between the weighing device and the barcode scanner can be established via the following ports: RS232 (1), RS232 (2), USB A.

Procedure:

- Enter **<Peripherals / Barcode Scanner / Port>** submenu and set respective port.

15.3.2. Offset

Parameter allowing you to set the first significant code's character, characters preceding the first significant character are skipped during comparison search.

Procedure:

- Enter **<Peripherals / Barcode Scanner / Offset>** submenu and, using the on-screen keyboard, enter a required value.

15.3.3. Length of Code

Parameter allowing you to set the number of code's characters to be taken into account during search procedure.

Procedure:

- Enter **<Peripherals / Barcode Scanner / Length of code>** submenu and, using the on-screen keyboard, enter a required value.

15.3.4. Prefix, Suffix

Parameter allowing you to edit **<Prefix>** and **<Suffix>** in order to provide synchronization of the scale program with a barcode scanner.

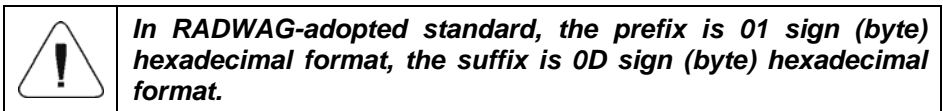

Procedure:

- Enter **<Peripherals / Barcode Scanner / Prefix>** submenu and, using the on-screen keyboard, enter a required value (hexadecimal format).
- Go to **<Suffix>** submenu and, using the on-screen keyboard, enter a required value (hexadecimal format).

15.3.5. Field Selection

Parameter allowing you to specify, for which field the search is to be carried out in particular databases.

Procedure:

- Enter **<Peripherals / Barcode Scanner / Field selection>** submenu, list of fields for search is displayed.

Available values: None, Product, Operator, Customer, Packaging, Lot number, Batch number.

15.3.6. Filtering

Parameter allowing you to declare search criteria.

Procedure:

- Enter **<Peripherals / Barcode Scanner / Filtering>** submenu, list of search criteria is displayed.

Filtering criteria conditioned by field type:

Field selection	Filtering
None	*
Product	Name, Code, Name 2, Code 2.
Operator	Name, Code.
Customer	Name, Code.
Packaging	Name, Code.
Lot number	**
Batch number	**

*) - <Filtering> submenu hidden. Function inactive.

***) - <Filtering> submenu hidden. Function active.

15.3.7. Test

Parameter allowing you to verify if operation of a barcode scanner connected to a scale is correct.

Procedure:

- Enter <Barcode Scanner / Test> submenu, <Test> edit box is displayed, it features ASCII field and HEX field.
- The code is scanned and entered to the ASCII field and HEX field, next the test result is displayed in the bottom part.

When:

- <Prefix> and <Suffix> declared in scale settings comply with <Prefix> and <Suffix> of the scanned code, the test result is <Positive>.
- <Prefix> and <Suffix> declared in scale settings do NOT comply with <Prefix> and <Suffix> of the scanned code, the test result is <Negative>.

15.4. Additional Display

Settings of connection between a scale and an external additional display.

15.4.1. Port

Communication between the weighing device and the additional display can be established via the following ports: RS232 (1), RS232 (2).

Procedure:

- Enter **<Peripherals / Additional display / Port>** submenu and select respective port.

	<i>Enter <Communication> submenu and set baud rate, mind that the set value must be accordant with the additional display (115200b/s).</i>
---	---

15.4.2. Bottom Text Area Template

Additional display features text area for extra information such as date, tare value etc. Displayed data content is set using the weighing device.

Procedure:

- Enter **<Peripherals / Additional display / Bottom text area template>** submenu, **<Bottom text area template>** edit box is displayed.
- Modify the template and press  key to confirm changes. The template can comprise 30 characters maximum.

16. PRINTOUTS

<Printouts> submenu allows you to:

- define template for header, GLP and footer printout,
- define report templates: adjustment, dosing, formulations.
- create 10 non-standard printouts.

16.1. Print Mode: Header – GLP Printout - Footer

Printout comprises 3 basic sections:

Header section	Group of parameters allowing you to declare variables that are to be printed on a header printout.
GLP printout section	Group of parameters allowing you to declare variables that are to be printed on a measurement printout.
Footer section	Group of parameters allowing you to declare variables that are to be printed on a footer printout.





For each section a customised list of printout variables has been specified. You must set respective option either enabling or disabling particular variable printing.

Variables list

HEADER	GLP printout	FOOTER
Dashes *	Date	Working mode
Working mode *	Time	Date
Date *	Operator	Time
Time *	Product	Scale type
Scale type	Customer	Scale S/N
Scale S/N	Packaging	Operator
Operator *	Universal variable 1	Product
Product *	Universal variable 2	Customer
Customer	Universal variable 3	Universal variable 1
Universal variable 1	Net	Universal variable 2
Universal variable 2	Tare	Universal variable 3
Universal variable 3	Gross	Dashes *
Empty line *	Current result *	Empty line *
Adjustment Report	Adjustment Report	Adjustment Report
Non-standard printout	Non-standard printout	Signature *
		Non-standard printout

*) – Variables accessible by default (marked with  pictogram).

How to Operate Printouts

1. To print variables comprised within **GLP printout** section which are enabled for printing and marked with  pictogram, press  key located on the weighing device panel.
2. To print variables comprised within **Header** and/or **Footer** section which are enabled for printing and marked with  pictogram, press respective programmable button:  **Header printout** and/or  **Footer printout**.

	<i>For detailed procedure informing you how to program buttons, read section 18.2.</i>
---	---

Variables description

Variable	Description
Working mode	Working mode name.
Scale type	Declared scale type.
Scale S/N	Serial number of the scale.
Operator	Logged-in operator name.
Product	Currently selected product name.
Customer	Currently selected customer name.

Packaging	Currently selected packaging names.
Date	Current date.
Time	Current time.
Net	Net weight value in a basic unit (calibration unit).
Tare	Tare weight value in the current unit.
Gross	Gross weight value in the current unit.
Universal variable 1	Value of universal variable 1.
Universal variable 2	Value of universal variable 2.
Universal variable 3	Value of universal variable 3.
Current result	Measurement result in a current unit.
Adjustment report	Adjustment report printed according to the settings declared for the adjustment report printout.
Dashes	Dashes separating printout data.
Empty line	Blank line.
Signature	An area for the signature of an operator carrying out the measurement.
Non-standard printout	One of 10 non-standard printouts.

Printout examples:

<pre> ----- Working modes Weighing Date 24.07.2013 Time 7:37:30 ScaleType AS Balance ID 10353870 User ADMIN ENG Product Tablet </pre>	<pre> Date 04.06.2013 Time 11:11:24 AM Product NAZWA 0.000 g </pre>	<pre> ----- Date 24.07.2013 Time 7:41:10 User ADMIN ENG Signature </pre>
<i>Header section</i>	<i>GLP printout section</i>	<i>Footer section</i>



16.2. Non-Standard Printouts

The program allows you to design 10 non-standard printouts. Each of them can consist of approximately 1900 characters (letters, digits, special signs, spaces), including:

- fixed texts,
- variables conditioned by a particular working mode and operator needs (mass, date, checkweighing thresholds).

	<p><i>For list of printout variables read ANNEX 01 of this user manual.</i></p>
---	--

Procedure for adding non-standard printout:

- Enter <Printouts / Non-standard printouts> submenu.
- Press  button (add record) assigned to  panel key, a new record is created, it is defined by the following data:

Name	Non-standard printout name (43 characters maximum).
Code	Non-standard printout code (15 characters maximum).
Project	Text editor of printout template (1900 characters maximum).

	<i>For detailed information regarding text box read section 10.3.</i>
---	--

16.3. Adjustment Report

Group of parameters allowing you to declare variables that are to be printed on an adjustment report printout. Adjustment report is automatically generated at the end of each adjustment process.

Variables description

Variable	Description
Project	Project name (31 characters maximum).
Adjustment type	Performed adjustment type.
Operator	Logged-in operator name.
Project	Project name printout.
Date	Adjustment performance date.
Time	Adjustment performance time.
Scale S/N	Serial number of the scale.
Adjustment result difference	Difference between mass of the adjustment weight that was measured during the last adjustment and mass of a currently measured adjustment weight.
Dashes	Dashed line separating printout data and signature fields.
Signature	An area for the signature of an operator carrying out the adjustment.

16.4. Dosing Report

Group of parameters allowing you to declare variables that are to be printed on a dosing report printout. Dosing report is generated automatically after either completion or abortion of each process.

Variables description

Variable	Description
Start date	Dosing process start date.
End date	Dosing process end date.
Operator	Operator carrying out the dosing process.
Customer	Customer for whom the dosing process is carried out.
Product	Name of dispensed product selected from <Products> database.
Fast dosing threshold [DT1]	Mass value for rough dosing in case of automatic 2-stage dispensing.
Dosing threshold [DT2]	Target mass value to be dosed in case of an automatic dispensing.
Dosing correction	Dosing correction value.
Dosing mass	Net value of mass that is to be dosed, given in an adjustment unit.
Difference	Difference between the net value of mass that is to be dosed and a value of automatic dosing threshold.
Min	Value of low threshold of manual dosing.
Max	Value of max threshold of manual dosing.
Status	Status of the dosing process, values: Ongoing , Completed , Aborted .
Dashes	Dashed line separating printout data and signature fields.
Signature	An area for the signature of an operator carrying out the dosing process.
Non-standard printout	One of 10 non-standard printouts.

16.5. Formulation Report

Group of parameters allowing you to declare variables that are to be printed on a formulation report printout. Formulation report is generated automatically after either completion or abortion of each process.

Variables description

Status	Formulation performance status. Status values: Ongoing , Aborted , Completed .
Start date	Formulation start date.
End date	Formulation end date.
Formulation	Performed formulation name.
Operator	Operator performing formulation process.

Customer	Customer for whom the formulation is carried out.
Ingredients quantity	Number of formulation ingredients.
Measurements quantity	Number of weighings performed within the formulation cycle.
Lot number	Lot number assigned to a formulation.
Measurements	List of weighings performed within the formulation cycle.
Target value	Sum of declared nominal masses of the ingredients.
Sum	Total weight value of the performed formulation.
Difference	Difference between the sum and the value of expected target weight.

17. INPUTS / OUTPUTS

Standard version of PUE C32 indicator is equipped with 4 inputs and 4 outputs.

In order to set inputs and outputs enter: <  / **Inputs/Outputs**> submenu.

17.1. Input Setup

- Enter <**Inputs/Outputs**> submenu.
- Select <**Inputs**> parameter and edit respective input, list of functions that can be assigned to the input is displayed. Input functions list is identical like key functions list, read section 18.2.
- Select the function you want to assign to the input, next go back to the home screen.

	<i>By default all functions are assigned with <None> value.</i>
--	--

17.2. Output Setup

Output gets activated at the moment of assigning it with a given function. Unassigned outputs remain inactive.



Procedure:

- Enter <**Inputs/Outputs**> submenu.
- Select <**Outputs**> parameter and edit respective output, list of functions that can be assigned to the output is displayed.

None	Output inactive.
Stable	Stable weighing result over LO threshold value.
MIN stable	Stable weighing result below the MIN threshold.

MIN unstable	Unstable weighing result below the MIN threshold.
OK stable	Stable weighing result between MIN and MAX thresholds.
OK unstable	Unstable weighing result between MIN and MAX thresholds.
MAX stable	Stable weighing result over the MAX threshold.
MAX unstable	Unstable weighing result over the MAX threshold.
Zero	Zero weighing result („zero” marker).
! OK unstable	Unstable weighing result out of OK threshold.
! OK stable	Stable weighing result out of OK threshold.
MIN	MIN threshold signalling.
OK	OK threshold signalling.
MAX	MAX threshold signalling.
Active process	Ongoing process signalling.

- Select the function you want to assign to the output, next go back to the home screen.

	<i>By default all functions are assigned with <None> value.</i>
	<i>For detailed description on how to set MIN, MAX thresholds refer to section 13.6.</i>

18. DISPLAY

You can customize the home screen and the displayed data. Customization concerns the workspace (fields 1, 2, 3, 4) and the bottom area (5) featuring programmable buttons with functions assigned to numeric keys of the operation panel:



In order to customize the screen go to <  / **Display**> submenu.

18.1. Workspace

Workspace of your weighing device can comprise the following widgets: label, text box, bar graph. Each working mode features default home screen widgets set. Available fields (**widgets**) dimensions (width x height):

- Label – 1x1; 2x1.
- Text box - 1x1; 2x1.
- Bar graph – 1x1; 2x1.

2x1 field size equals size of two 1x1 fields (1 and 2 or 3 and 4). The program automatically detects suitable widget size matching particular area. The widgets are displayed in declared fields after completing data setup and leaving 'Settings' menu.

18.1.1. Label

Field displaying information updated in a real time in the course of weighing device operation (selected product name, gross weight value, etc.). **<Workspace components>** submenu for a field comprising **<Label>** widget features the following options:

Information	Enter this parameter to read info on selected widget type and dimensions.
Settings	Enter this parameter to specify which widget-assigned data is to be displayed.
Delete	Enter this parameter to delete the widget. Upon entering, a respective warning is displayed: <Delete?> . Press  key to confirm.
Add	Option available only if the widget has not been added yet. Upon entering <Add> submenu you can select <Label> widget of particular dimensions.

Label data list (data accessibility is conditioned by a working mode).

					
Net					
Tare					
Gross					
Operator					
Product					
Packaging					
Customer					
Lot number					
Batch number					
Universal variable 1					
Universal variable 2					

Universal variable 3	✓	✓	✓	✓	✓
Date	✓	✓	✓	✓	✓
Time	✓	✓	✓	✓	✓
Date and Time	✓	✓	✓	✓	✓
Thresholds	✓	✓	✓		
MIN threshold	✓	✓	✓		
MAX threshold	✓	✓	✓		
Number	✓	✓	✓		
Sum	✗	✓	✓		
Gross sum	✓	✓	✓		
Average	✓	✓	✓		
Min	✓	✓	✓		
Max	✓	✓	✓		
SDV	✓	✓	✓		
Net	✓	✓	✓		
Gross	✓	✓	✓		
Part mass		✗			
Reference mass			✗		
Status				✓	✓
Formulation					✗
Ingredient					✗

✗ - Default label settings.

18.1.2. Text Box

Field displaying weighing-related information. As an operator you can freely program the field content (texts and variables of line 1 and line 2).

	<i>For detailed information regarding text box read section 10.3.2. For list of printout variables read ANNEX 01 of this user manual.</i>
---	--

<Workspace components> submenu for a field comprising <Text box> widget features the following parameters:

Information	Enter this parameter to read info on selected widget type and dimensions.
Settings	Enter this parameter to specify which widget-assigned data is to be displayed. Upon entering this parameter line 1 and line 2 settings are displayed. Lines 1, 2 can comprise 45 characters maximum.

Delete	Enter this parameter to delete the widget. Upon entering, a respective warning is displayed: <Delete?> . Press <input type="checkbox"/> key to confirm.
Add	Option available only if the widget has not been added yet. Upon entering <Add> submenu you can select <Text field> widget of particular dimensions.

18.1.3. Bar Graph

Bar graph is available for all working modes. It is a graphic visualisation informing you how much of the weighing device capacity is used. It allows you to observe whether the load stays within the specified Max capacity or is out of it. Additionally it shows:

- position of **Min** and **Max** thresholds in **<Weighing>**, **<Parts Counting>**, **<Percent weighing>** working modes.
- position of **dosing thresholds** in dosing process (read section 29.3 of this manual).
- position of **percent weighing** range in formulation process (read section 30.4 of this manual).

<Workspace components> submenu for a field comprising **<Bar graph>** widget features the following parameters:

Information	Enter this parameter to read info on selected widget type and dimensions.
Settings	This submenu provides two functions: 1. Bar graph type: Linear (linear presentation of the weighing range); 2. Zoom: Enabling/disabling bar graph zoom in order to provide more clear visualisation of the 'Min threshold' - 'Max threshold' range.
Delete	Enter this parameter to delete the widget. Upon entering, a respective warning is displayed: <Delete?> . Press <input type="checkbox"/> key to confirm.
Add	Option available only if the widget has not been added yet. Upon entering <Add> submenu you can select <Bar graph> widget of particular dimensions.

Bar graph operation, MIN and MAX thresholds displayed:

Bar graph provides you with a linear presentation of the weighing range.



Additionally it shows where Min and Max thresholds are (providing that they were declared).

- Visualisation of mass value lower than MIN value:



Min=1600g

Max=1800g

- Visualisation of mass value higher than MIN value and lower than MAX value:



Min=1600g

Max=1800g

- Visualisation of mass value higher than MIN value and lower than MAX value, **<Zoom>** option on:



Min=1600g

Max=1800g

- Visualisation of mass value higher than MAX value:



Min=1600g

Max=1800g

	<p><i>MAX threshold value has to be greater than MIN threshold value.</i></p>
	<p><i>For detailed description on how to set MIN, MAX thresholds refer to section 13.6.</i></p>































18.2. Keys



















Programmable numeric keys (0 - 9). These are so called quick access keys for triggering the most often performed operations. Numeric keys 1 - 5 are additionally provided with graphic symbol which you can see in the bottom bar of the display.

Procedure:

- Enter **<Display / Buttons functions>** submenu, edit a respective key.
- Select the function you want to assign to the key, next go back to the home screen.

Key functions list (function accessibility is conditioned by a working mode).

	Function	Working modes				
						
	Working mode parameters	✓	✓	✓	✓	✓
	Select product	✓	✓	✓	✓	✓
	Select formulation					✓
	Select packaging	✓	✓	✓	✓	✓
	Select customer	✓	✓	✓	✓	✓
	Set tare	✓	✓	✓	✓	✓
	Set MIN and MAX	✓	✓	✓	✓	✓
	Print header	✓	✓	✓	✓	✓
	Print footer	✓	✓	✓	✓	✓
	Statistics: Zero	✓	✓	✓	✓	✓
	Statistics: Print	✓	✓	✓	✓	✓
	Statistics: Print and zero	✓	✓	✓	✓	✓
	Edit labels quantity	✓	✓	✓	✓	✓
	Edit C labels quantity	✓	✓	✓	✓	✓
	Edit lot number	✓	✓	✓	✓	✓
	Edit batch number	✓	✓	✓	✓	✓
	Edit universal variable 1	✓	✓	✓	✓	✓
	Edit universal variable 2	✓	✓	✓	✓	✓
	Edit universal variable 3	✓	✓	✓	✓	✓
	Databases	✓	✓	✓	✓	✓
	Reports	✓	✓	✓	✓	✓
	Select operator	✓	✓	✓	✓	✓
	Print	✓	✓	✓	✓	✓
	Zero	✓	✓	✓	✓	✓
	Tare	✓	✓	✓	✓	✓

	Parameters	✓	✓	✓	✓	✓
	Change working mode	✓	✓	✓	✓	✓
	Change unit	✓				
	Last digit	✓				
	Set date	✓	✓	✓	✓	✓
	Set time	✓	✓	✓	✓	✓
	Set part mass		✓			
	Determine part mass		✓			
	Assign reference sample		✓			
	Reference sample quantity - 5pcs.		✓			
	Reference sample quantity – 10pcs.		✓			
	Reference sample quantity – 20pcs.		✓			
	Reference sample quantity – 50pcs.		✓			
	Reference sample quantity – 100pcs.		✓			
	Set reference sample mass			✓		
	Determine reference sample mass			✓		
	Process start				✓	✓
	Process stop				✓	✓
	Process pause				✓	✓
	Breakdown				✓	
	None	✓	✓	✓	✓	✓

✓ - Default settings.

18.3. Default Screen Settings

Function allowing you to set default workspace values and default function keys for a particular working mode.

Procedure:

- Enter **<Display / Default screen settings>** submenu, a respective warning is displayed: **<Continue?>**.
- Press  key to confirm.

- Default workspace values and default function keys for a particular working mode are set. Next, **<Display>** submenu is shown automatically.

19. PERMISSION LEVELS

<Permissions> submenu is available for operators logged as **Administrator**. This group of parameters allows you to determine access rights for particular operators. In order to set permission levels enter **<**  **/ Permissions>** submenu.

19.1. Anonymous Operator

Parameter allowing you to assign unlogged weighing device operator (so called anonymous operator) with permission level.

Procedure:

- Enter **<Permissions / Anonymous operator>** submenu.
- Set one of four options: None, Operator, Advanced operator, Administrator.

19.2. Date and Time

Default scale settings enable operator who is logged as **Administrator** to modify date and time parameter. but the software allows to change permission level, and as a result authorize other operators to access **<Date and time>** parameter.

Procedure:

- Enter **<Permissions / Date and time>** submenu.
- Set one of four options: None, Operator, Advanced operator, Administrator.

	<p><i>When <None> option is set, all unlogged operators can set date and time.</i></p>
---	---

19.3. Printouts

Default scale settings enable operator who is logged as **Administrator** to edit printouts but the software allows to change permission level, and as a result authorize other operators to access **<Printouts>** parameter.

Procedure:

- Enter **<Permissions / Printouts>** submenu.
- Set one of four options: None, Operator, Advanced operator, Administrator.

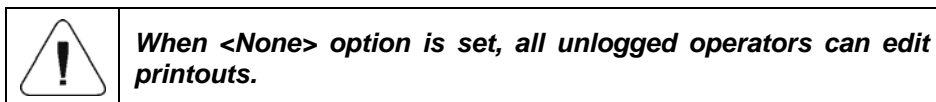

19.4. Databases Edition

Parameter allowing you to set permission levels enabling particular operators to edit the following databases: products, formulations, packaging, customers, universal variables.

Procedure:

- Enter **<Permissions / Databases edition>** submenu.
- Select respective database and set one of four options: None, Operator, Advanced operator, Administrator.

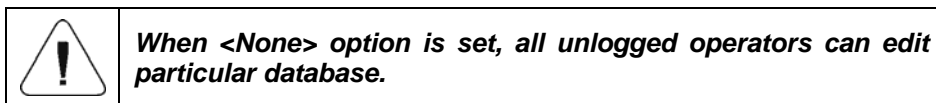

19.5. Select Database Record

Parameter allowing you to set permission levels enabling particular operators to select given database records. 'Select database record' parameter is available for the following databases: products, formulations, packaging, customers, universal variables.

Procedure:

- Enter **<Permissions / Select database record>** submenu.
- Select respective database and set one of four options: None, Operator, Advanced operator, Administrator.

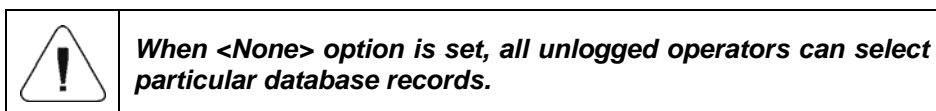

20. UNITS

Option available for the Weighing mode exclusively

<Units> submenu allows you to:

- set particular units accessibility,
- set start unit,
- define two custom units,
- change gravitational acceleration value.

In order to set units enter <  / **Units**> submenu.



Accessibility of particular units is conditioned by weighing device status; i.e. it depends on the fact whether the given scale is verified or not.

20.1. Units Availability

Parameter allowing to declare which units are to be accessible upon pressing



key.

Procedure:

- Enter **<Units / Availability>** submenu.
- Units list is displayed, mark units of your choice as available (✓ - Unit enabled, ✗ - Unit disabled).

20.2. Start Unit

Upon setting start unit, the scale activates with the set start unit for these modes where change of the unit is possible.

Procedure:

- Enter **<Units>** submenu, next enter **<Start unit activation>** parameter.
- Go to **<Start unit>** submenu and select start unit from the list.
- Go back to the home screen and restart the weighing device.
- After restart, the weighing device runs with the declared start unit.

20.3. Gravitational Acceleration

<Gravitational acceleration> parameter compensates changes of gravity force being a result of different latitude and altitude when the selected unit is „Newton” [N].

Procedure:

- Enter **<Units / Gravitational acceleration>** submenu, **<Gravitational acceleration>** edit box is displayed.
- Enter gravitational acceleration value respective for the particular place of use and press  key to confirm changes.

20.4. Custom Units

Option available for non-verified scales exclusively

Parameter allowing you to declare two custom units. Displayed custom unit value is a result of calculation, where obtained in the course of measurement weight value is multiplied by a multiplier determined for this particular custom unit. By default the custom units are marked as: **[u1]** – custom unit 1 and **[u2]** – custom unit 2.

Procedure:

- Enter **<Units / Custom unit 1>** submenu, set the following parameters:

Name	Unit name (3 characters maximum).
Multiplier	Adjustment unit multiplier.

- Go to the home screen.
- Now you can use the custom unit, to do it press  key.

	<i>Procedure for declaring <Custom unit 2> is analogous.</i>
---	---

21. MISCELLANEOUS PARAMETERS

Parameters facilitating scale operation. To set these parameters go to **<**  **/ Misc>** submenu.

21.1. Interface Language

Parameter allowing you to set program menu language.

Procedure:

- Enter **<Misc / Language>** submenu and set the interface language.

Available languages: Polish, English, German, French, Spanish, Czech.

21.2. 'Beep' Sound

Parameter allowing to enable/disable sound signal informing the operator about pressing panel key(s).

Procedure:

- Enter **<Misc / Sounds>** submenu and set respective option.

Where:

	Sound signal enabled.
	Sound signal disabled.

21.3. Display Brightness

Parameter allowing you to change display brightness, the brightness can be changed within **0% - 100%** range.

Procedure:

- Enter **<Misc / Display brightness>** submenu and set respective value.

Available values: 0%, 10%, 20%, 30%, 40%, 50%, 60%, 70%, 80%, 90%, **100%** (set by default).

21.4. Proximity Sensors Sensitivity

Parameter allowing you to adjust distance within which the proximity sensors are to be operated. The distance can be adjusted within 0% - 100% range, for lower values the proximity sensors operate at a shorter distance.

Procedure:

- Enter **<Misc / Proximity sensors sensitivity>** submenu and set respective value.

Available values: 0%, 10%, 20%, 30%, 40%, **50%** (set by default), 60%, 70%, 80%, 90%, 100%.

21.5. Date and Time

Parameter allowing you to set current date and time, and to specify date and time format.

Procedure:

- Enter **<Misc / Date and time>** submenu and change the settings. Refer to the below table:

Parameter	Description
Date	Enter this parameter to set current date.
Time	Enter this parameter to set current time.
Date format *	Enter this parameter to set date format. Options: YYYY.MM.DD (set by default), YYYY.DD.MM, DD.MM.YYYY, MM.DD.YYYY, YYYY/MM/DD, YYYY/DD/MM, DD/MM/YYYY, MM/DD/YYYY, YYYY-MM-DD, YYYY-DD-MM, DD-MM-YYYY, MM-DD-YYYY.
Time format **	Enter this parameter to set time format. Options: HH:mm:ss 24H (set by default), HH:mm:ss 12H, HH-mm-ss 24H, HH-mm-ss 12H, HH.mm.ss 24H, HH.mm.ss 12H.

*) *Date format symbols: Y – year, M – month, D – day.*

**) *Time format symbols: HH – hour, mm – minute, ss – second, 24H – 24-hour mode, 12H – 12-hour mode.*

21.6. Backlight Standby Time

Parameter allowing you to set time interval, in [min], after which the screen goes black.

Procedure:

- Enter **<Misc / Backlight standby time>** submenu and set respective value.

Available values: None (set by default), 0.5, 1, 2, 3, 5.

21.7. Automatic Shutdown

Parameter allowing you to set time interval, in [min], after which the weighing device shuts down automatically. If the indication is stable during the declared time interval, the automatic shutdown occurs. Shutdown function is inactive and the device cannot be turned off when any of the processes is ongoing or when the menu is operated.

Procedure:

- Enter **<Misc / Automatic shutdown>** submenu and set respective value.

Available values: None (set by default), 1, 2, 3, 5, 10.

21.8. Default Operator Settings

Parameter allowing you to restore default operator settings.

Procedure:

- Enter **<Misc / Restore default operator settings>** submenu, a respective warning is displayed: **<Continue?>**.
- Press  key to confirm. Message **<Please wait...>** is displayed, the operation is in progress.
- After completed operation **<Misc>** submenu is displayed.

22. ADJUSTMENT



Option available for non-verified scales exclusively

In order to ensure the highest weighing accuracy, it is recommended to periodically introduce a corrective factor of indications to weighing device memory, the said factor must be referred to the reference mass. Adjustment has to be carried out prior first weighing or if the ambient temperature has changed dynamically. Prior adjustment unload the weighing pan.

22.1. External Adjustment

External adjustment is carried out using an external mass standard of the right accuracy and weight value, which value depends on scale type and capacity. Correction is carried out semi-automatically, successive process stages are signalled with prompts.

Procedure:

- Enter **<Adjustment / External adjustment>** submenu. Message **<Remove weight>** is displayed.
- Unload the weighing pan and press  key, message **<Adjustment; Please wait...>** is displayed.
- Upon completed start mass determination, message **<Put weight>** is displayed along with particular value of mass standard assigned to the scale.
- Load the weighing pan with the required adjustment weight and press  key.
- Upon completed procedure, message **<Remove weight>** is displayed.
- Take the weight off the weighing pan, the scale displays the **<Adjustment>** submenu.

22.2. User Adjustment

User adjustment can be carried out using any adjustment weight, mass of which ranges between: **0.3 Max - Max**.

To run user adjustment procedure enter **<Adjustment / User adjustment>** submenu. User adjustment and external adjustment procedures are likewise with one exception, before user adjustment start, an edit box for entering mass of the used adjustment weight is opened.

22.3. Start Mass Determination

If the weighing device does not require adjustment or you do not have suitable amount of adjustment weights, you can only determine start mass.

Procedure:

- Enter **<Adjustment / Start mass determination>** submenu. Message **<Remove weight>** is displayed.
- Unload the weighing pan and press  key, message **<Start mass determination; Please wait...>** is displayed.
- Upon completion of start mass determination procedure, the scale displays the **<Adjustment>** submenu.

22.4. Adjustment Report

Adjustment report is automatically generated at the end of each adjustment process, next it is sent to port selected for **<Peripherals / Printer>**. To declare report content go to **<Printouts / Adjustment report>** submenu. For instruction on how to declare adjustment report settings read section 'Printouts'.

Report example:



```
-----Adjustment report-----  
Adjustment type           External  
Operator                  Nowak Jan  
Date                      2018.04.10  
Time                      13:22:28  
Scale S/N                 123456  
Adjustment result difference 0.0g  
-----  
Signature  
.....
```

23. SCALE DATA

Scale data menu provides information on the weighing device and its program. The parameters serve informative purposes: scale S/N, scale type, software version, product code, settings printout. In order to send weighing device settings (all parameters) to printer port, select **<Settings printout>** parameter.

24. WORKING MODES - GENERAL INFORMATION

The weighing device features the following working modes:

	Weighing
	Parts counting
	Percent weighing
	Dosing
	Formulations

24.1. Running Working Mode

- Go to the home screen and press  key, **<Working modes>** submenu providing list of available working modes is displayed.
- Select the working mode you need to operate, the home screen is displayed automatically, wherein the top bar of the screen features pictogram of the selected mode.



24.2. Working Mode Accessibility

You can declare which working modes are to be accessible for an operator upon pressing  key.

Procedure:





- Enter **<Working modes / Accessibility>** submenu and make given working modes accessible.

Where:



	Working mode accessible.
	Working mode inaccessible.

25. WORKING MODES - Local Settings

In order to set working modes' parameters enter <  / **Working Modes**> submenu. Particular working modes feature specific functions. The functions enable adapting mode operation to your individual needs. Some of the specific functions are global, i.e. they are applied for all accessible working modes, refer to the table below:



					
Readout	✓	✓	✓	✓	✓
Proximity sensors	✓	✓	✓	✓	✓
Save mode	✓	✓	✓	-	-
Auto Threshold	✓	✓	✓	✓	-
Result control	✓	✓	✓	-	-
Autotare	✓	✓	✓	-	-
Labelling mode	✓	✓	✓	-	-
Statistics	✓	✓	✓	-	-

Remaining specific functions referring directly to a given working mode are described further down this user manual.

	<p>On-screen button  (working mode parameters) that is to be found in each working mode home screen, provides direct access to settings of the given working mode.</p>
---	--

25.1. Readout

Readout submenu comprises functions allowing you to adjust your weighing device to ambient conditions of a given workstation.

Filter	Enter this parameter to adjust your weighing device to ambient conditions. The higher filter level, the longer the indication takes to stabilise. Options: Very fast, Fast, Average, Slow, Very slow.
Value Release	Enter this parameter to adjust rate of stabilisation of the measurement result. Depending on the selected option, weighing time is either shorter or longer. Options: Fast, Fast plus reliable, Reliable.
Autozero	Enter this parameter to enable automatic control and correction of zero indication. There are, however, some cases when this function can be a disturbing factor for the measuring process. e.g. very slow placing of a load on the weighing pan (load adding, e.g. pouring, filling). In such case, it is recommended to disable the function. Options:  - function disabled,  - function enabled.

Last digit	Enter this parameter to enable/disable display of the last digit (placed on the right of the decimal point) of the weighing result. Options: Always : all digits are displayed; Never : last digit disabled; When stable : last digit displayed only when the result is stable.
Ambient conditions	Parameter relating to ambient and environmental conditions of the workstation. Enter this parameter and set 'unstable' value if the ambient conditions are unfavourable (air drafts, vibrations). Options: Stable , Unstable .

25.2. Proximity Sensors

The weighing device is equipped with two proximity sensors which enable touch free control. The program detects two motions performed around the sensors:

1. Hand in a close vicinity to the left sensor **<Left sensor>**.
2. Hand in a close vicinity to the right sensor **<Right sensor>**.

Each motion can trigger optional weighing device function. For available functions list read section 18.2.

Upon completed configuration procedure, the software runs function assigned to a particular proximity sensor, having detected motion around it. To provide correct operation, it is necessary to set respective proximity sensors sensitivity (read section 21.4).

25.3. Save Mode

Parameter allowing you to set mode of sending data from the weighing device to a peripheral device.

Procedure:

- Enter **<Working modes>** menu and select respective working mode.
- Enter **<Save mode>** submenu and select respective save mode.

Save mode options list:

Manual each stable	Manual printout of each stable weighing result above <Auto threshold> .
Manual first stable	Manual printout of the first stable weighing result above <Auto threshold> .
Automatic first stable	Automatic printout of the first stable weighing result above <Auto threshold> .
Automatic last stable	Automatic printout of the last stable weighing result detected upon the weight value gets below <Auto threshold> .

Semi-automatic each stable	Manual printout of each weighing result, where the weight value is above -LO- threshold; this option requires awaiting for the stable weighing result.
Semi-automatic first stable	Manual printout of the first weighing result, where the weight value is above -LO- threshold; this option requires awaiting for the stable weighing result.



25.4. Auto Threshold

<Auto threshold> parameter allows you to configure the function of automatic operation. The next measurement is saved when mass indication gets below the set net value of **<Auto threshold>** parameter.

Procedure:

- Enter **<Working modes>** submenu and select respective working mode.
- Enter **<Auto threshold>** submenu and provide respective value, next press  key to confirm changes.

25.5. Result Control



When your weighing device operates with 'result control' mode on, the printout is carried out only when mass of load placed on the weighing pan is comprised within **MIN**, **MAX** thresholds. If the 'result control' mode is on, respective pictograms are displayed on the right of the weighing result window, , ,







Procedure:

- Enter **<Working modes>** menu and select respective working mode.
- Enter **<Result control>** submenu and set respective option.

Where:

	Each weighing is recorded.
	Weighings between MIN, MAX thresholds are recorded.

	<i>For detailed description on how to set MIN, MAX thresholds refer to section 13.6.</i>
	<i>For MIN=0 and MAX=0 , ,  pictograms are inactive.</i>

25.6. Autotare

Autotare function allows you to quickly determine net weight for loads with different tare values, which loads are measured one after another. When **<Autotare>** function is on, the operation cycle takes the following steps:

- Make sure that the weighing pan is empty and press zeroing key.
- Load the weighing pan with product packaging (packaging weight value must be greater than the set value of **<Auto threshold>** parameter).
- Upon indication stabilization, packaging mass is **automatically tared** (**NET** pictogram is displayed in the upper part of the display).
- Put/pour/dispense product that is to be packed into the packaging.
- Unload the weighing pan (remove both product and packaging).
- When the weighing device detects weight value lower than **<Auto threshold>** value, the entered tare value gets automatically deleted (**NET** pictogram is no longer displayed).
- When you load the weighing pan with a new product packaging, analogous set of operations proceeds.

25.7. Labelling Mode

Labelling system is designed to print labels for product marking. The program generates standard labels, for single products, and cumulative labels, for bulk boxes.

Custom functions of <Labelling mode> submenu:



Labels quantity	Parameter for declaring number of labels to be printed on the scale-connected printer.
C labels quantity	Parameter for declaring number of C labels to be printed on the scale-connected printer.
Automatic C label triggering	For detailed description read section 25.7.1.

25.7.1. Automatic C Label Triggering



Automatic C Label Triggering function allows to trigger printout of C label, to do it you must define **<Mode>** and **<Threshold>** parameters.

Procedure:



- Enter **<Working modes>** submenu and select respective working mode.
- Go to **<Labelling mode / Automatic C label triggering / Mode>** parameter and set respective option, where:

None	Manual printout of C label *, performed upon pressing either  or  button.
Mass	Automatic printout of C label, triggered upon exceeding of the total mass value of the single labels, set in <Threshold> parameter.
Number	Automatic printout of C label, triggered upon exceeding single labels quantity, set in <Threshold> parameter.

*) Manual printout of C labels is carried out using one of the two below programmable buttons:

	Printout with zeroing (weighings qty. and total mass values are zeroed).
	Printout without zeroing (weighings qty. and total mass values are not zeroed).

	<i>In case of automatic printout of C labels, counter zeroing function is always on (weighings qty. and total mass values are always zeroed).</i>
---	--

- To confirm introduced modifications, press  key and go to **<Threshold>** parameter, **<Threshold>** edit box opens.
- Set the value that is to trigger C label printout, mind that:
 - in case of **<Mode>** parameter set to **<Mass>** value, you must provide total mass value, upon obtaining of which you want the C label printout to be triggered,
 - in case of **<Mode>** parameter set to **<Counter>** value, you must provide quantity value, upon obtaining of which you want the C label printout to be triggered.
- Press  key to confirm introduced modifications.

25.8. Statistics

All statistical data is updated in an ongoing manner. The statistical data can be updated globally (regardless of the weighted product) or individually for each product that is either weighed or selected from the database.

Procedure:

- Enter **<Working modes>** submenu and select respective working mode.
- Go to **<Statistics>** parameter and set respective option.

Where:

Global	Update of statistical data carried out globally.
Product	Update of statistical data carried out individually for each product, either weighed or selected from the database.

26. WORKING MODE – WEIGHING

<Weighing> is a standard working mode enabling you to carry out the weighing operation along with record of the result to the database.

26.1. Home Screen

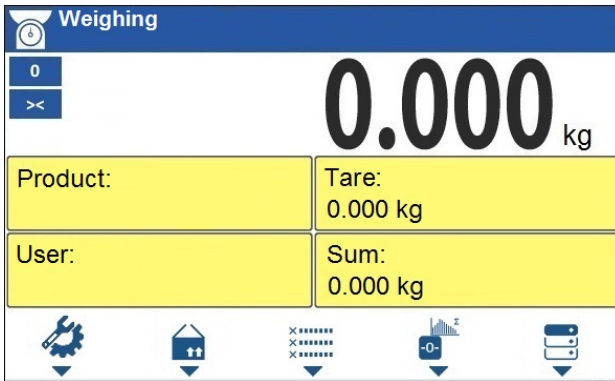

26.2. Local Settings

In order to access local settings, press operation panel key to which < Working mode parameters> pictogram is assigned:

Readout	For detailed description read section 25.1.
Proximity sensors	For detailed description read section 25.2.
Save mode	For detailed description read section 25.3.
Auto Threshold	For detailed description read section 25.4.
Result control	For detailed description read section 25.5.
Autotare	For detailed description read section 25.6.
Labelling mode	For detailed description read section 25.7.
Statistics	For detailed description read section 25.8.

27. WORKING MODE – PARTS COUNTING

<Parts counting> is a working mode enabling you to determine quantity of small pieces of the same mass, which determination is done on the basis of reference weight value of single piece, either determined using the weighing device or taken from the database.

27.1. Home Screen

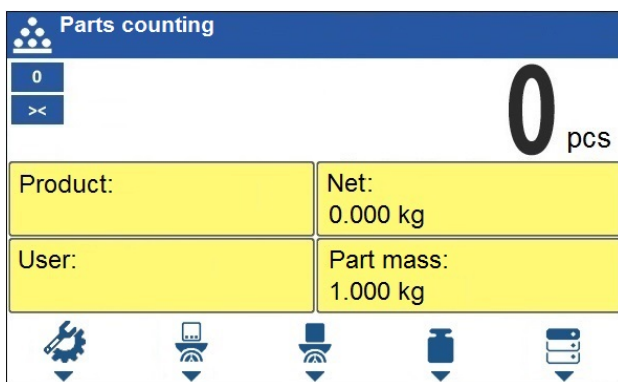

27.2. Local Settings

In order to access local settings, press operation panel key to which Working mode parameters> pictogram is assigned:

ACAI	For detailed description read section 27.2.1.
Minimum Reference Sample Mass	For detailed description read section 27.2.2.
Readout	For detailed description read section 25.1.
Proximity sensors	For detailed description read section 25.2.
Save mode	For detailed description read section 25.3.
Auto Threshold	For detailed description read section 25.4.
Result control	For detailed description read section 25.5.
Autotare	For detailed description read section 25.6.
Labelling mode	For detailed description read section 25.7.
Statistics	For detailed description read section 25.8.



27.2.1. Function of Automatic Correction of Reference Sample Mass

<ACAI> is a specific function enabling you to correct weight value of a single piece by means of the weighing device program.

Procedure:

- Enter <Working modes / Parts counting / ACAI> submenu and set respective option.

Where:

	Function of automatic correction of reference sample mass disabled.
	Function of automatic correction of reference sample mass enabled.

<ACAI> function gets activated for <Parts counting> mode at the moment of determination of reference sample quantity, it is signalled by display of  pictogram at the home screen top bar.

There are four conditions of ACAI function operation implemented into the weighing device program:

1. the weighing result must be stable,
2. pieces quantity must increase,
3. pieces quantity upon adding cannot increase more than twice,
4. pieces quantity upon adding must be comprised within ± 0.3 tolerance of total value.

If you decide that the reference sample features the right amount of pieces, you can record weight value of a single piece to weighing device memory and deactivate the function by pressing  key.

27.2.2. Minimum Reference Sample Mass

Prior determining single piece weight value you can declare „**Minimum reference sample mass**, i.e. minimum weight value for the total mass of all pieces loaded onto the weighing pan, expressed in reading units.

Procedure:



- Enter <Working modes / Parts counting / Minimum reference sample mass> submenu and set respective option.

Available values: 1 d, 2 d, 5 d, 10 d.



Total mass of all the pieces loaded onto the weighing pan must not be lower than value declared in „Minimum reference sample mass” parameter. Unless this condition is met, the weighing device displays a message: <Sample mass too low>.

27.3. Setting Reference Sample Mass by Entering Mass of a Single Part

- Press  button (Set part mass), **<Reference sample mass>** edit box featuring an on-screen keyboard is displayed.
- Enter respective value and press  key to confirm, **<Parts counting>** working mode is run with automatically set mass of a single part.







If the value of entered single part mass is greater than max capacity value, then the following message is displayed: <Value too high>.



If the value of entered single part mass is lower than 0.1 of the reading unit, then the following message is displayed: <Value too low>.



27.4. Setting Reference Sample Mass by Determining Mass of a Single Part

If the parts are to be weighed in a container, first put the container on a weighing pan and tare it.

- Press  button (Determine part mass), **<Reference sample quantity>** edit box featuring an on-screen keyboard is displayed.
- Enter respective value and press  key to confirm, the following message is displayed: **<Number of parts to be loaded: xx>** (where **xx** – previously entered value).
- Load the weighing pan with declared amount of parts. When the indication is stable ( pictogram is displayed), press  key to confirm the mass.
- Single part mass is calculated automatically, **<Parts counting>** working mode is run and the weighing device displays quantity of single parts (**pcs**).



Total weight value of all parts loaded onto the weighing pan cannot be greater than the max capacity value.

	<p>Total weight value of all parts loaded onto the weighing pan cannot be lower than the value determined by „Minimum reference sample mass” parameter. Unless this condition is met, the weighing device displays a message: <Sample mass too low>.</p>
	<p>Single part mass must be equal or greater than 0.1 reading unit. Unless this condition is met, the weighing device displays a message: <Single part mass too low>.</p>

27.5. Setting Reference Sample Mass by Acquiring Mass of a Single Part from Database

Upon selecting a product from database, single part mass assigned to the product (<Part mass> entry) is entered automatically.

Procedure:



- Enter <Parts counting> mode and press operation panel key to which  pictogram (product database) is assigned, next select given product from the list.

	<p>Weight value of a single part must be declared for the selected product. To declare weight value of a single part, enter products database and edit the selected product.</p>
---	---

27.6. Entering Reference Sample Mass to Weighing Device Memory

Reference sample mass of single part can be entered to products database.

Procedure:

- Press  button, select the given product.
- Determine reference sample mass (read sections 27.3 and 27.4 of this user manual).
- Press  button (Assign reference sample), reference sample mass for the product is recorded in <Part mass> entry.

28. WORKING MODE - PERCENT WEIGHING

Percent weighing is a working mode enabling you to compare the measured sample with the reference mass. The result is expressed in [%]. Reference mass can be either determined by weighing or entered to weighing device memory by an operator.

28.1. Home Screen

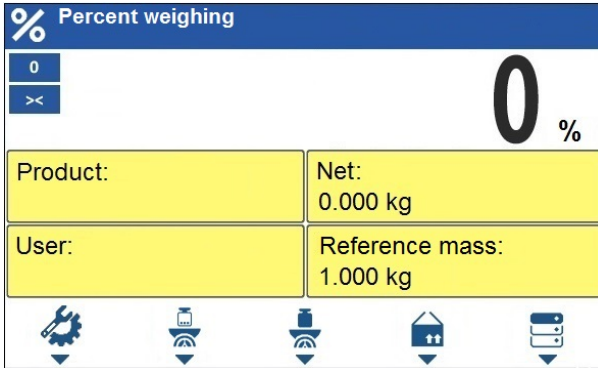



28.2. Local Settings

In order to access local settings, press operation panel key to which  **Working mode parameters**> pictogram is assigned:



Readout	For detailed description read section 25.1.
Proximity sensors	For detailed description read section 25.2.
Save mode	For detailed description read section 25.3.
Auto Threshold	For detailed description read section 25.4.
Result control	For detailed description read section 25.5.
Autotare	For detailed description read section 25.6.
Labelling mode	For detailed description read section 25.7.
Statistics	For detailed description read section 25.8.

28.3. Reference Sample Mass Determined by Weighing

If the reference sample is to be weighed in a container, first put the container on a weighing pan and tare it.

- Press  button (Determine reference sample mass), the following message is displayed: **<Put reference sample>**.
- Load the weighing pan with reference mass. When the indication is stable ( pictogram is displayed) press  key to confirm the value.
- Now (instead of weight value of the measured load) difference between values of loaded mass and reference mass is displayed in [%].

28.4. Reference Sample Mass Entered to the Weighing Device Memory

- Press  button (Set part mass), **<Set reference sample mass>** edit box featuring an on-screen keyboard is displayed.
- Enter respective value and press  key to confirm changes.
- Now (instead of weight value of the measured load) difference between values of loaded mass and reference mass is displayed in [%].

28.5. Setting Reference Sample Mass by Acquiring Mass of a Single Part from Database

Upon selecting a product from database, reference sample mass of single part assigned to the product (**<Reference sample mass>** entry) is entered automatically.

Procedure:

- Enter **<Percent weighing>** mode and press operation panel key to which  pictogram (products database) is assigned, next select given product from the list.
- Difference between values of loaded mass and reference mass assigned to a selected product is displayed in [%].

29. WORKING MODE – DOSING

Dosing is a working mode enabling you to dispense product. Two options are available, manual and automated dispensing.

29.1. Home Screen

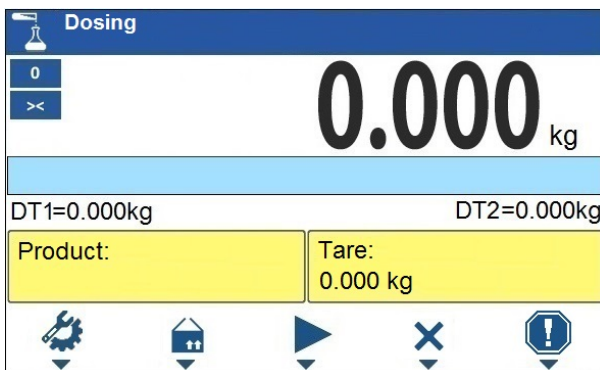

29.2. Local Settings

In order to access local settings, press operation panel key to which  **Working mode parameters** pictogram is assigned:

Procedure:

- Enter <  / **Working modes / Dosing** > submenu.
- Select <**Dosing mode**> parameter and set one of the dosing modes:

Manual dosing	Manual dosing with MIN, MAX thresholds.
Automatic dosing	Automatic 1-, 2-stage dosing with automated activation of dosing outputs.

- List of available dosing functions changes depending on the selected dosing mode.

List of automatic dosing functions







Fast dosing threshold [DT1]	Enter to set mass value for rough dosing in case of automatic 2-stage dispensing.
Dosing threshold [DT2]	Enter to set target mass value to be dosed in case of an automatic dispensing.
Fast dosing output	Enter to declare outputs for rough dosing in case of automatic 2-stage dispensing.
Dosing outputs	Enter to declare outputs for precise dosing in case of automatic 2-stage dispensing.
Chute outputs	Enter to activate chute; signalling informing that the silos is being emptied switches on.
Permission to start	Enter to send signal triggering process START.
Permission to empty	Enter to send signal triggering the process of silos emptying (e.g. opening of flap).
Chute delay [s]	Enter to set process end delay, counted from the moment when mass value gets below the set < Auto threshold > value.
Record delay [s]	Enter to set delay of record of dosed mass after the dosing threshold gets reached. The parameter value is declared in [s], value range is 0 [s] (function inactive) - 300 [s].
Request cycles quantity	Enter to force query regarding number of dosing process cycles, i.e. to specify how many times the whole process is to be repeated.
Request mass	Enter to force query regarding value of mass that is to be dosed after process start.
Automatic taring	Enter to enable/disable automatic taring at the moment of dosing process start.

Dosing correction	Enter to correct the dosed mass, this function allows to optimise the dosing process, change of pressure of dosed material in the silos is accounted for. Parameters: Constant correction – specifying global (constant) value of correction to be applied during each process; Maximum correction – specifying maximum value of correction, which can be determined automatically during the process; Measurements quantity for correction calculation – specifying how many of the most recent measurements is to be analysed in order to automatically calculate the correction during the process.
Readout	For detailed description read section 25.1.
Proximity sensors	For detailed description read section 25.2.
Auto Threshold	For detailed description read section 25.4.

List of manual dosing functions

Min	Enter to set the value of low threshold of manual dosing.
Max	Enter to set the value of max threshold of manual dosing.
Confirm ingredients manually	Mark to enforce manual confirmation of dosed mass by means of pressing  key (the function is enabled for manual dosing mode).
Automatic taring	Enter to enable/disable automatic taring at the moment of dosing process start.
Readout	For detailed description read section 25.1.
Proximity sensors	For detailed description read section 25.2.
Auto Threshold	For detailed description read section 25.4.

29.3. Automatic Dosing Procedure

- Save general parameters of Dosing mode to scale memory, the parameters are to be found upon pressing a key to which  pictogram is assigned.
- In case of selecting a product (that is to be dosed) from the database the following message is displayed: **<Fast dosing threshold, dosing threshold, dosing outputs, fast dosing outputs will be obtained from the product data. Continue?>** ( - press to select,  - press to cancel).
- Press key to which  pictogram (process start) is assigned, now scale keypad is locked except for  - stop,  - pause,  - breakdown keys.

When:

1. Dosing outputs are declared incorrectly (e.g. lack of active dosing output) the following message is displayed: **<Dosing outputs determined incorrectly>**, next the process is cancelled.
 2. The weighing result is unstable then the following message is displayed: **<Unstable weighing result>**. The process status changes to **PS=Pause** and remains so until stable weighing result is obtained.
- Upon process start, bar graph of dosed material mass is displayed with the following data:







Top bar pictograms:

	process in progress (blinking pictogram).
--	---

Workspace data:

DT1	Fast dosing threshold value.
DT2	Dosing threshold value.
Product	Name of a product that is to be dosed.
Tare	Tare value (mass of container, silos, etc.).
PS	Process status, the status takes the following values: -3.000kg – amount left to be dosed; OK – target dosing mass obtained; Pause – process inhibited: a) by means of (pause) button, to restart the process press button, b) start signal is awaited for, c) container emptying signal is awaited for; Taring – taring process in progress; 00:00:05 [s] - automatic countdown of time delay for record of dosed mass, or automatic countdown of time delay for process end; Chute – pending for silos emptying; Completed – dosing completed; Aborted – dosing aborted.

Buttons that are assigned to operation panel keys:

	Local parameters (button inactive during the ongoing process).
	Product selection.
	Process start.
	Process stop.
	Breakdown stop.

Bar graph functioning, 1-stage automatic dosing:

- Visualisation of mass value lower than the value of **[DT2]** threshold:



DT1=0g

DT2=1800g

- Visualisation of mass value higher than the value of **[DT2]** threshold:



DT1=0g

DT2=1800g

Bar graph functioning, 2-stage automatic dosing:

- Visualisation of mass value lower than the value of **[DT1]** threshold:



DT1=1600g

DT2=1800g

- Visualisation of mass value higher than the value of **[DT1]** threshold and lower than the value of **[DT2]** threshold:



DT1=1600g

DT2=1800g

- Visualisation of mass value higher than the value of **[DT2]** threshold:







DT1=1600 g

DT2=1800 g

- Upon exceeding the value of fast dosing threshold, fast dosing outputs are activated.

- Upon exceeding the value of dosing threshold, dosing outputs are activated and **PS=OK** process status is displayed.
- In case of active time delay, countdown of declared time starts.
- After countdown completion, **PS=Completed** status is displayed (process completed). Blinking pictogram  is turned off.

29.4. Manual Dosing Procedure

- Save general parameters of Dosing mode to scale memory, the parameters are to be found upon pressing a key to which  pictogram is assigned.
- Press key to which  pictogram (process start) is assigned, scale keypad is locked except for  - stop,  - pause,  - breakdown keys.

When:



1. Dosing outputs are declared incorrectly (e.g. lack of active MIN or MAX outputs) the following message is displayed: **<Dosing outputs determined incorrectly>**, next the process is cancelled.
 2. The weighing result is unstable then the following message is displayed: **<Unstable weighing result>**. The process status changes to **PS=Pause** and remains so until stable weighing result is obtained.
- Upon process start, bar graph of dosed material mass is displayed with the following data:







Top bar pictograms:



	process in progress (blinking pictogram).
---	---

Workspace data:

Min	Value of low threshold of manual dosing.
Max	Value of max threshold of manual dosing.
PS	Process status, the status takes the following values: -3.000kg – amount left to be dosed; OK – target dosing mass comprised between MIN and MAX thresholds; Pause – process inhibited by  (pause) button, to restart the process press  button; Taring – taring process in progress; Completed – dosing completed; Aborted – dosing aborted.
Product	Name of a product that is to be dosed.
Tare	Tare value (mass of container, silos, etc.).

Buttons that are assigned to operation panel keys:

	Local parameters (button inactive during the ongoing process).
	Product selection (button inactive during the ongoing process).
	Process start.
	Process stop.
	Breakdown stop.

- If dosed mass value is between **MIN** and **MAX** thresholds then **PS=OK** status is displayed.
- In case of active **<Confirm ingredients manually>** function, the user must confirm mass value manually by pressing  key.
- Press  key to confirm dosed mass, **PS=Completed** status is displayed (process completed). Blinking pictogram  is turned off.

29.5. Dosing Process Report

Dosing report is automatically generated at the end of each dosing process, next it is sent to port selected for **<Peripherals / Printer>**. To declare report content go to **<Printouts / Dosing report>** submenu. For instruction on how to declare adjustment report settings read section 'Printouts'.

Report example:

```
-----Dosing Report-----
Start date      2018.07.10 13:21:40
End date       2018.07.10 13:23:28
Operator       Nowak Jan
Fast dosing threshold [DT1]  2.800 kg
Dosing threshold [DT2]     3.000 kg
Dosing mass    3.018 kg
Difference     0.018 kg
Status        Completed
-----
```

Signature
.....

Report on each completed process is saved to **<Dosing reports>** database, the file name is a combination of date and hour of process completion and of process status (list of dosing report data – read section 32.3.3).

30. WORKING MODE – FORMULATIONS

Formulations is a working mode enabling you to make multi-ingredient mixture.

30.1. Home Screen

Formulations

0 >< 0.000 kg

LD=0.000kg HD=0.000kg

Formulation: Ingredient:

⚙️ 📄 ▶️ ✕ ⏸️



30.2. Local Settings

In order to access local settings, press operation panel key to which **<⚙️ Working mode parameters>** pictogram is assigned:

Request multiplier	Enter to force query regarding formulation multiplier, i.e. value by which the weight, high deviation and low deviation values of <mass> type are to be multiplied.
---------------------------	---

Request cycles quantity	Enter to force query regarding number of formulation process cycles, i.e. to specify how many times the whole process is to be repeated.
Request lot number	Enter to provide series number for formulation.
Confirm ingredients manually	Enter to enforce manual confirmation for each weighing by pressing of  key.
Automatic taring	Enter to enable automatic taring at the moment of formulation start, and after weighing of each ingredient.
Readout	For detailed description read section 25.1.
Proximity sensors	For detailed description read section 25.2.

30.3. New Formulation

- Enter <  **Databases / Formulations**> submenu.
- Press operation panel key to which  (add) pictogram is assigned. New record is automatically edited. For list of new formulation data read section 31.6.3 of this manual.
- Enter <**Ingredients**> submenu, add formulation ingredients one by one, do it by pressing key to which  (add) pictogram is assigned.



List of ingredient data:

Name	Ingredient name (43 characters maximum).
Code	Ingredient code (16 characters maximum).
Mass	Target mass of the ingredient.
Deviation type	Declared deviation type: unit of mass or value in [%].
High deviation	High deviation of ingredient mass in 'Formulations' mode.
Low deviation	Low deviation of ingredient mass in 'Formulations' mode.
Weight entered manually	Manual mode for entering ingredient mass (ingredient is not weighed).



	<i>Formulation ingredients are acquired from <Products> database.</i>
---	--

- Modification of ingredient settings is possible upon editing of the selected ingredient, to do it press key to which  (edit) pictogram is assigned.

When

1. you declare low deviation of value greater than the declared ingredient mass then the following message is displayed: **<Value too high>**. Enter correct low deviation value.
 2. you declare high deviation of value greater than the declared ingredient mass then the following message is displayed: **<Value too high>**. Enter correct high deviation value.
- Enter the required data and press  button, the new ingredient is added to the formulation.
 - Enter the last ingredient and go to the home screen, do it by pressing  key.

30.4. Formulation Procedure

- Select the formulation, do it by pressing key to which  (select formulation) pictogram is assigned.
- Save general parameters of Formulations mode to scale memory, the parameters are to be found upon pressing a key to which  pictogram is assigned.
- Press key to which  (process start) pictogram is assigned.

When:

1. The declared value of formulation multiplier causes exceeding of the max capacity value, then the following message is displayed: **<Formulation multiplier value too high>**. The process gets cancelled.
 2. The declared value of ingredient mass exceeds the max capacity value, then the following message is displayed: **<Ingredient mass value higher than max capacity value>**. The process gets cancelled.
 3. Sum of ingredient mass and high deviation values exceeds the max capacity value, then the following message is displayed: **<High deviation value too high>**. The process gets cancelled.
 4. The weighing result is unstable then the following message is displayed: **<Unstable weighing result>**. The process status changes to **PS=Pause** and remains so until stable weighing result is obtained.
- Upon process start, bar graph of weighed ingredient mass is displayed with the following data:

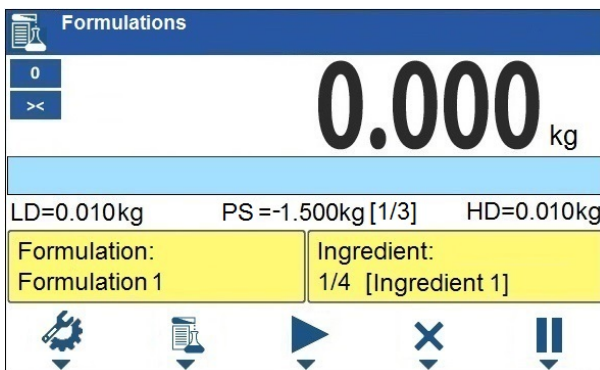

Top bar pictograms:

	process in progress (blinking pictogram).
--	---

Workspace data:

LD	Low deviation value.
HD	High deviation value.
PS	Process status, the status takes the following values: -3.000kg – amount left to be weighed; [1/3] – cycle 1 of 3; OK – target mass obtained; Pause – process inhibited: a) by means of (pause) button, to restart the process press button, b) stable weighing result is awaited for, Taring – taring process in progress; Completed – formulation process completed; Aborted – formulation process aborted.
Formulation	Formulation name.
Ingredient	Information regarding weighed formulation ingredient: 1 – ingredient no., 4 – ingredients quantity, [Ingredient 1] – ingredient name.

Buttons that are assigned to operation panel keys:

	Local parameters (button inactive during the ongoing process).
	Select formulation (button inactive during of the ongoing process).
	Process start (button inactive during the ongoing process).
	Process stop.
	Process pause.

Bar graph operation:

- Visualisation of mass value lower than the value of **[LD]**, low deviation:

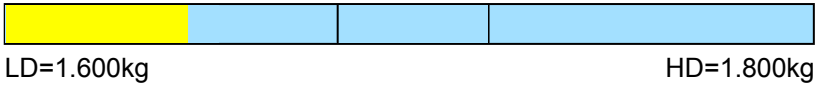

- Visualisation of mass value higher than the value of **[LD]**, low deviation and lower than the value of **[HD]**, high deviation:



- Visualisation of mass value higher than the value of **[HD]**, high deviation:



- Weigh expected amount of each ingredient.

	<p><i>In the case of trying to accept unstable weighing result, the following message is displayed: <Unstable measurements>.</i></p>
---	---

- After weighing of the last ingredient, **PS=Completed** status is displayed (process completed).
- New formulation process may begin.

30.5. Formulation Report

Formulation report is automatically generated at the end of each formulation process, next it is sent to port selected for **<Peripherals / Printer>**. To declare report content go to **<Printouts / Formulation report>** submenu. For instruction on how to declare adjustment report settings read section 'Printouts'.

Report example:

```

-----Formulation report-----
Start date      2018.07.10 13:21:40
End date       2018.07.10 13:23:28
Operator              Nowak Jan
Ingredients quantity          2
Measurements quantity        2
Target value              3.000 kg
Sum                       3.018 kg
Difference                 0.018 kg
Status                    Completed
-----

```

Signature

.....

Report on each completed process is saved to **<Formulation reports>** database, the file name is a combination of date and hour of process completion and of process status (for the list of dosing report data read section 32.3.4).

31. DATABASES

Weighing device software comprises the following databases:

Database name	Max records qty
Products	15000
Operators	500
Formulations	500
Packaging	500
Customers	500
Labels	500
Universal variables	100



In order to configure databases, enter <  / **Databases**> submenu.

	<i>Databases editing is available for operators logged as Administrator.</i>
---	---

31.1. Database Export

Export of weighing device databases carried out using USB flash drive.

Procedure:



- Enter selected database.
- Activate function keys, to do it press  key.
- Connect the USB flash drive to the USB A port.
- Press operation panel key to which  pictogram (export) is assigned.
- The program automatically saves exported data to a USB flash drive file, respective messages are displayed to confirm successfully completed operation.
- The file name is correlated with the name of exported database:

Databases	File name and extension
Operators	Users.idb32
Products	Products.idb32
Formulations	Formulas.idb32
Packaging	Packages.idb32
Customers	Customers.idb32
Labels	Labels.idb32
Universal variables	Universal variables.idb32
Non-standard printouts	Non standard printouts.idb32



31.2. Database Import

Import of weighing device databases carried out using USB flash drive.

Procedure:

- Enter selected database.
- Activate function keys, to do it press  key.
- Connect the USB flash drive to the USB A port.
- Press key to which  pictogram (import) is assigned. Databases stored on the USB flash drive are imported to the weighing instrument memory automatically.
- Respective messages are displayed to confirm successfully completed operation.

31.3. Adding Database Record



- Enter selected database.
- Activate function keys, to do it press  key.
- Press operation panel key to which  (add) pictogram is assigned. New record is automatically edited.

31.4. Deleting Database Record

- Enter selected database.
- Activate function keys, to do it press  key.
- Press operation panel key to which  pictogram (delete one by one) is assigned. Message **<Delete record?>** is displayed.

- Press  key to confirm. The selected record gets deleted.

31.5. Deleting Database Content

- Enter selected database.
- Activate function keys, to do it press  key.
- Press key to which  pictogram (delete all database records) is assigned. Message **<Delete all records?>** is displayed.
- Press  key to confirm. All database records get deleted.

31.6. Databases Edition

31.6.1. Operators

Operators database features list of users permissioned to operate the weighing device.

List of parameters defined for an operator:

Name	Operator name (43 characters maximum).
Code	Operator code (15 characters maximum).
Password	Operator password, used in the course of logging in operation (15 characters maximum).
Permissions	Operator's permission levels (Administrator, Advanced Operator, Operator, None).

31.6.2. Products

Product database stores names of all products that can be weighed, counted, controlled.

List of parameters defined for a product:

Name	Product name (43 characters maximum).
Code	Product code (15 characters maximum).
Name 2	Additional name (43 characters maximum).
Code 2	Additional code (15 characters maximum).
Min ³⁾	Low limit of weighing within ranges (Result control).
Max ³⁾	High limit of weighing within ranges (Result control).
Tare	Tare value (set automatically when the product is selected).
Mass ¹⁾	Nominal value of product mass.

Deviation type ⁴⁾	Declared deviation type: unit of mass or value in [%].
Low deviation ⁴⁾	Low deviation of ingredient mass in 'Formulations' mode.
High deviation ⁴⁾	High deviation of ingredient mass in 'Formulations' mode.
Fast dosing threshold ²⁾	Mass value for rough dosing in case of automatic 2-stage dispensing.
Dosing threshold ²⁾	Target mass value to be dosed.
Dosing outputs ²⁾	Outputs for precise dosing in case of automatic 2-stage dispensing.
Fast dosing outputs ²⁾	Outputs for rough dosing in case of automatic 2-stage dispensing.
Dosing correction ²⁾	Constant dosing correction value.
Price	Unit price of a product.
VAT	VAT value given in [%].
Shelf-life time in days	Shelf-life time of a product (number of days).
Label	Template of a single label assigned to a product.
C Label	Template of a cumulative label assigned to a product.
Weight entered manually ⁴⁾	Manual mode for entering ingredient mass (ingredient is not weighed).

1)	Variable name is conditioned by the working mode. For Weighing and Dosing modes the variable name is „ Mass “. For Parts Counting mode the variable name is „ Part mass “. For Percent Weighing mode the variable name is „ Reference sample mass “.
2)	Variables available for product in Dosing working mode.
3)	Variables NOT available for product in Formulations working mode.
4)	Variables available for product exclusively in Formulations working mode.

31.6.3. Formulations

Formulations database features list of formulations that can be carried out automatically by particular ingredients weighing.

List of parameters defined for a formulation:

Name	Formulation name (43 characters maximum).
Code	Formulation code (15 characters maximum).
Ingredients	Defining formulation ingredients, and preview of added formulation ingredients quantity.
Target value	Preview of total mass of formulation.

31.6.4. Packaging

Packaging database features list of product containers. When carrying out weighing process, upon selection of particular packaging, a respective tare value is triggered automatically. The tare value is displayed with minus sign.

List of parameters defined for a packaging:

Name	Packaging name (43 characters maximum).
Code	Packaging code (15 characters maximum).
Mass	Packaging weight value (set automatically when the packaging is selected).

31.6.5. Customers

Customers database features a list of names of customers for whom the measurements are carried out.

List of parameters defined for a customer:

Name	Customer name (43 characters maximum).
Code	Customer code (15 characters maximum).
TIN	Tax identification number (15 characters maximum).
Address	Customer address (43 characters maximum).
Postal code	Customer postal code (7 characters maximum).
City	Customer city (43 characters maximum).
Discount	Discount for a customer given in [%].
Label	Template of a label assigned to a customer.

31.6.6. Labels

Labels database features a list of label templates that can be assigned to a product or a customer in order to activate operation in labelling mode.

List of parameters defined for a label:

Name	Label name.
Code	Label code.
Project *	Label project.

) An example of how to make and send label template to a scale memory is to be found in **ANNEX 02 of this user manual.*

31.6.7. Universal Variables

Universal variables database comprises universal variables templates. You can assign the templates to function keys. This allows you to easily enter any text/number/letter, that you want to print, to weighing device memory.

Values of 3 universal variables V_1 , V_2 , V_3 , entered to weighing device memory will be saved to a completed weighing record.

List of parameters defined for a universal variable:

Code	Universal variable code (15 characters maximum).
Name	Universal variable name (43 characters maximum).
Value	Universal variable value, it is to be printed and/or saved to weighing record (32 characters maximum).

32. REPORTS

Weighing device software comprises the following reports:

Report name	Max records qty
Weighings	50000
Alibi	500000
Dosing reports	5000
Formulations reports	5000



In order to preview, export and delete reports, enter <  / Reports > submenu.

	<i>Database of Alibi reports is protected against deletion.</i>
---	--

32.1. Export of Reports

Export of reports carried out using USB flash drive.

Procedure:

- Enter selected reports database.
- Activate function keys, to do it press  key.
- Connect the USB flash drive to the USB A port.
- Press operation panel key to which  pictogram (export) is assigned.

- The program automatically saves exported data to a USB flash drive file, respective messages are displayed to confirm successfully completed operation.
- The file name is correlated with the name of exported reports database:



Reports database	File name and extension
Weighings	xxxxxx.wei
Alibi	xxxxxx.ali
Dosing reports	xxxxxx.dos
Formulations reports	xxxxxx.for

Where: xxxxxx – weighing device serial number.

Files can be read using **ALIBI Reader**, PC software designed by RADWAG. You can download the software from RADWAG website: www.radwag.pl.

32.2. Deleting Reports

N/a in case of Alibi reports database.

- Enter reports database.
- Activate function keys, to do it press  key.
- Press key to which  pictogram (delete all records of report database) is assigned. Message **<Delete all records?>** is displayed.
- Press  key to confirm. All database records get deleted.

32.3. Reports Preview

32.3.1. Weighings

Each weighing result sent from the weighing device to a printer is saved to weighings report. You can preview data of particular weighings.

List of parameters defined for a completed weighing

Date	Performed weighing date.
Time	Performed weighing time.
Stable	Stable weighing result marker
Result	Weighing result given in specific unit (% , pcs).
Mass	Net weight.
Tare	Tare value.
Operator	Operator name.

Product	Product name.
Customer	Customer name.
Lot number	Lot number (16 characters maximum).
Batch number	Batch number (16 characters maximum).
Result control	Weighing result range.
Min	Minimum weighing result threshold (result control).
Max	Maximum weighing result threshold (result control).
Universal variable 1	Value of universal variable 1.
Universal variable 2	Value of universal variable 2.
Universal variable 3	Value of universal variable 3.

32.3.2. Alibi

Each weighing result sent from the weighing device to a printer is saved to Alibi report. You can preview data of particular weighings.

List of parameters defined for a completed weighing

Date	Performed weighing date.
Time	Performed weighing time.
Result	Weighing result given in specific unit (% , pcs).
Mass	Net weight.
Tare	Tare value.

32.3.3. Dosing

Dosing report is generated automatically after completion of each dosing process. You can preview data for particular reports.

Status	Information regarding correctness of dosing process realisation. Status values: Aborted , Completed .
Start date	Date of dosing process start.
End date	Date of dosing process end.
Operator	Operator carrying out the dosing process.
Customer	Customer for whom the dosing process is carried out.
Dosing mass	Dosed net weight in an adjustment unit.
Dosing threshold	Target mass value to be dosed.
Fast dosing threshold	Mass value for rough dosing in case of automatic 2-stage dispensing.

Correction	Current value of correction in an automatic dosing.
Difference	Difference between the net value of mass that is to be dosed and a value of automatic dosing threshold.
Min	Value of low threshold of manual dosing.
Max	Value of max threshold of manual dosing.

32.3.4. Formulations

Formulation report is generated automatically after completion of each formulation process. You can preview data for particular reports.

Status	Formulation performance status. Status values: Ongoing, Aborted, Completed.
Start date	Formulation start date.
End date	Formulation end date.
Formulation	Performed formulation name.
Operator	Operator performing formulation process.
Customer	Customer for whom the formulation is carried out.
Ingredients quantity	Number of formulation ingredients.
Measurements quantity	Number of weighings performed within the formulation cycle.
Lot number	Lot number assigned to a formulation.
Measurements	List of weighings performed within the formulation cycle.
Target value	Sum of declared nominal masses of the ingredients.
Sum	Total weight value of the performed formulation.
Difference	Difference between the sum and the value of expected target weight.

33. IMPORT / EXPORT

Import/export option facilitates the following:

- archiving of reports,
- copying databases between weighing devices of the same series,
- copying parameters between weighing devices of the same series.

Import/export operation can be carried out by means of USB flash drive comprising **<FAT files system>**.

Procedure:

- Connect the USB flash drive to the USB A port.
- The weighing device detects USB flash drive automatically, as a result **<Import / Export>** box is displayed.

33.1. Data Export

Function designed to allow export of databases and/or user parameters.

<Export> submenu comprises the following functions:

- All databases,
- Products,
- Operators,
- Formulations,
- Packaging,
- Customers,
- Non-standard printouts,
- Universal variables,
- Weighings,
- Alibi,
- Dosing processes,
- Parameters.

When you run **<All databases>** function, files storing particular databases data are saved to USB flash drive, the files names are correlated with databases names.

The files extensions are specific (read section 'Databases Export', 32.1), file-stored data is encoded therefore the files content is not readable for standard computer programs. Data stored in weighings and Alibi reports files can be read using special RADWAG-designed PC software.

33.2. Data Import

<Import> function allows you to copy databases and operator's parameters between weighing devices of the same series. It is both quick and reliable method of entering data error-free. **<Import>** submenu comprises the following functions:

- All databases,
- Products,
- Operators,
- Formulations,
- Packaging,
- Customers,
- Non-standard printouts,
- Universal variables,
- Parameters.



Reports data cannot be imported.

SCALE
DSUB15/M

PT0128

Signals from scale
pin1 - GND_IN
pin2 - OUT1
pin3 - OUT2
pin4 - COMM
pin6 - IN4
pin7 - IN3
pin8 - TxDC
pin9 - 5VDC
pin10 - GNDRS
pin11 - IN2
pin12 - IN1
pin13 - RxDC
pin14 - OUT4
pin15 - OUT3

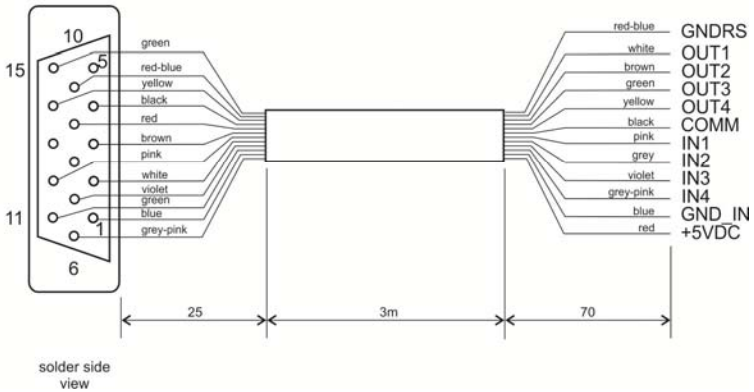

I/O cable



„Scale-Ethernet” cable is a standard network cable terminated with RJ45 connectors on both ends.

35. TECHNICAL SPECIFICATIONS

Maximum quantity of verification units	6000
Maximum impedance of load cell	1200 Ω
Minimum impedance of load cell	50 Ω
Maximum voltage per verification unit	3.25 μ V
Minimum voltage per verification unit	0.4 μ V
Connection of load cells	4 or 6 wires + shield
Load cell excitation voltage	5V DC
Maximum signal gain	19.5 mV
Display	5" colour graphic display
Protection Class	IP43
Housing	ABS plastic
Maximum number of connected platforms	1
Power supply	10 \div 16VDC
Operating temperature	0°C + 40°C
Communication Interfaces	2xRS232, USB A, USB B, Ethernet, wireless communication, 4I/O (option)
Multi range option	YES

36. ERROR MESSAGES



Max weighing threshold exceeded
Unload the weighing pan



Min weighing threshold exceeded
Install weighing pan



Zeroing out of range
Press tarring button or restart the balance



Display capacity out of range
Unload the weighing pan



Tarring out of range
Press zeroing button or restart the balance



Start mass out of range
Install weighing pan



Zeroing/tarring time out of range
Weighing indication unstable

37. ANNEX 01 – Printout Variables

37.1. Variables List

	<p><i>Each defined variable must be inserted in between curly bracket: {x}, where x – variable number.</i></p>
---	---

List of variables defining non-standard printout templates and data displayed within the workspace.

No.	Description
{0}	Standard printout in an adjustment unit
{1}	Standard printout in a current unit
{2}	Date
{3}	Time
{4}	Date and Time
{6}	Net weight in a current unit
{7}	Net weight in an adjustment unit
{8}	Gross weight
{9}	Tare
{10}	Current unit
{11}	Adjustment unit
{12}	Min threshold
{13}	Max threshold
{14}	Lot number
{15}	Statistics: Number
{16}	Statistics: Sum
{17}	Statistics: Average
{18}	Statistics: Min
{19}	Statistics: Max
{20}	Statistics: Gross sum
{21}	Gross weight value in the current unit
{22}	Net weight in [lb] unit
{23}	Result control (status)
{24}	Net price
{25}	Gross price
{26}	Total net price
{32}	Serial number
{33}	Reading unit
{34}	Range (Max capacity)
{35}	Parts counting: Reference sample mass
{36}	Percent weighing: Reference sample mass
{37}	Statistics: Standard deviation

{39} ¹⁾	Universal variable: Value
{41}	Batch number: Value
{45}	Parts counting: Reference sample quantity
{49} ¹⁾	Universal variable: Name
{50}	Product: Name
{51}	Product: Code
{52}	Product: Name 2
{53}	Product: Code 2
{54}	Product: Mass
{55}	Product: Price
{56}	Product: Tare
{57}	Product: Min
{58}	Product: Max
{59}	Product: Shelf-life time in days
{60}	Product: VAT
{62}	Product: Expiry date (current date + shelf-life time in days)
{75}	Operator: Name
{76}	Operator: Code
{77}	Operator: Permissions
{80}	Packaging: Name
{81}	Packaging: Code
{82}	Packaging: Mass
{85}	Customer: Name
{86}	Customer: Code
{87}	Customer: TIN
{88}	Customer: Address
{89}	Customer: Postal code
{90}	Customer: City
{91}	Customer: Discount in%
{100}	Dosing Report: Start date
{101}	Dosing Report: End date
{102}	Dosing Report: Fast dosing threshold
{103}	Dosing Report: Dosing threshold
{104}	Dosing Report: Dosing correction
{105}	Dosing Report: Dosing mass
{106}	Dosing Report: Difference
{107}	Dosing Report: Status
{120}	Formulation report: Formulation name
{121}	Formulation report: Formulation code
{122}	Formulation report: Start date
{123}	Formulation report: End date
{124}	Formulation report: Ingredients quantity
{125}	Formulation report: Measurements quantity
{126}	Formulation report: Sum

{127}	Formulation report: Difference
{128}	Formulation report: Status

	<i>For {39}, {49} variables, each database entry (1,2-n) must be formatted as follows: Entry 1 - {39:1}, {49:1}, Entry 2 - {39:2}, {49:2}, etc.</i>
---	--

37.2. Variables Formatting

You can format numeric variables, text variables and dates which are to be printed or displayed in the grey workspace.

Formatting types:

- variables with left justification,
- variables with right justification,
- determining quantity of characters for printing / displaying,
- determining quantity of decimal places for numeric variables,
- converting the format of date and hour,
- converting numeric variables into EAN13 code,
- converting numeric variables and date into EAN128 code.

Special formatting characters:

Character	Description	Example
,	Sign separating variable from format item.	{7,10} - Net weight value of fixed length (10 characters), given in an adjustment unit, right justification.
-	Either minus sign or left justification.	{7,-10} - Net weight value of fixed length (10 characters), given in an adjustment unit, left justification.
:	Either sign proceeding format item or time separator (inserted between hour, minute and second).	{7:F3} - Net weight value given in an adjustment unit, always with three decimal places. {3:HH:mm:ss 24H} - Current time in format: hour-minute-second.
F	Either sign formatting digits to a string of “-ddd.ddd...” format (where: d - single digit, minus - for negative values only) or determination of decimal places quantity.	{7:F2} - Net weight value given in an adjustment unit, always with two decimal places. {7,9:F2} - Net weight value of fixed length (9 characters), given in an adjustment unit, always with two decimal places, right justification.
V	Formatting mass and quantities being derivatives of mass in EAN13 code.	{7:V6.3} - Net mass in a form of EAN13 code (6-character code) with three decimal places.
T	Formatting mass and quantities being derivatives of mass in EAN128 code.	{7:T6.3} - Net mass in a form of EAN128 code with three decimal places.

/	Date separator separating days, months and years.	{2:yyyy/MM/dd} – Current date in format: year/month/day.
.	Date separator separating day, month and year, and time separator separating hour, minute and second.	{2:yyyy.MM.dd} – Current date in format: year.month.day. {3:HH.mm.ss 24H} – Current time in format: hour.minute.second.
-	Dash as a date separator between day, month and year, or as a time separator between hour, minute and second.	{2:yyyy-MM-dd} – Current date in format: year-month-day. {3:HH-mm-ss 24H} – Current time in format: hour-minute-second.

Formatted variables application:

CODE	DESCRIPTION
{6:V6.3}	Net weight value in a current unit in EAN 13 code (6-character code)
{6:V7.3}	Net weight value in a current unit in EAN 13 code (7-character code)
{7:V6.3}	Net weight value in an adjustment unit in EAN 13 code (6-character code)
{7:V7.3}	Net weight value in an adjustment unit in EAN 13 code (7-character code)
{8:V6.3}	Gross weight value in an adjustment unit in EAN 13 code (6-character code)
{8:V7.3}	Gross weight value in an adjustment unit in EAN 13 code (7-character code)
{16:V6.3}	Total net weight value in EAN 13 code (6-character code)
{16:V7.3}	Total net weight value in EAN 13 code (7-character code)
{20:V6.3}	Total gross weight value in EAN 13 code (6-character code)
{20:V7.3}	Total gross weight value in EAN 13 code (7-character code)
{21:V6.3}	Gross weight value in a current unit in EAN 13 code (6-character code)
{21:V7.3}	Gross weight value in a current unit in EAN 13 code (7-character code)
{24:V6.3}	Net amount due in EAN 13 code (6-character code)
{24:V7.3}	Net amount due in EAN 13 code (7-character code)
{25:V6.3}	Gross amount due in EAN 13 code (6-character code)
{25:V7.3}	Gross amount due in EAN 13 code (7-character code)
{26:V6.3}	Total net amount due in EAN 13 code (6-character code)
{26:V7.3}	Total net amount due in EAN 13 code (7-character code)
{6:T6.3}	Net weight value in a current unit in EAN 128
{7:T6.3}	Net weight value in an adjustment unit in EAN 128
{8:T6.3}	Gross weight value in an adjustment unit in EAN 128
{16:T6.3}	Total net weight value in EAN 128 code
{20:T6.3}	Total gross weight value in EAN 128 code
{22:T6.3}	Net weight value (lb) in EAN 128 code
{55:T6.2}	Product price in EAN 128 code
{2:YYMMDD}	Date in EAN 128 code
{62:YYMMDD}	Product expiry date in EAN 128 code

38. ANNEX 02 – Label Template

Label template can be created:

- via scale, using available variables,
- via **Label Editor R02** PC software.







For detailed description concerning creation of label template via PC software, read user manual of „Label Editor R02”.

In order to work in label scale mode, assign a label with template to a particular product or customer.

38.1. Creation of Label Template via the Scale

- Enter **<Databases / Labels>** submenu and select respective entry.
- Enter **<Project>** parameter, **<Project>** edit box is displayed.
- Modify selected label project and press  key to confirm.

38.2. Sending Label Template to Scale Memory

- Copy label template with *.lb extension, made using „Label Editor R02”, onto the USB flash drive.
- Connect the USB flash drive to scale's USB port.
- Enter **<Databases / Labels>** submenu and select respective entry.
- Enter **<Project>** parameter, **<Project>** edit box is displayed.
- Press  key to change keypad working mode, run  mode (bottom bar operation).
- Press  key that is a counterpart of  pictogram (import), box with USB flash drive content is displayed.
- Select previously copied label template with *.lb extension, the scale program inserts selected template into the edit box.
- Press  key to confirm.

38.3. Assigning a Label with a Template to a Product

- Enter **<Databases / Products>** submenu and select respective entry.
- Enter **<Label>** parameter, label database with list of existing labels is displayed.
- Select respective label, it is automatically assigned to a product.



38.4. Assigning a C Label with a Template to a Product



- Enter **<Databases / Products>** submenu and select respective entry.
- Enter **<C Label>** parameter, label database with list of existing C labels is displayed.
- Select respective label, it is automatically assigned to a product.

38.5. Assigning a Label with a Template to a Customer

- Enter **<Databases / Customers>** submenu and select respective entry.
- Enter **<Label>** parameter, label database with list of existing labels is displayed.
- Select respective label, it is automatically assigned to a customer.

38.6. Printing a Label with a Template

- Go to the home screen, select a product or a customer with a label assigned from a database.
- Load the weighing pan, wait for a  pictogram to display, press  key.
- The label is printed via scale-connected printer.

	<p><i>The label can be assigned to a product or a customer. Label template assigned to the most recently selected database entry (a product or a customer) is printed on a scale-connected printer upon pressing  key.</i></p>
---	---

39. ANNEX 03 - ZEBRA Printer Configuration

Transmission parameters	Printout data regarding RS232
Baud rate – 9600 b/sec Parity control – none Bits qty – 8 bits Stop bits – 1 bit	Serial port : 96, N, 8, 1

For detailed procedure specifying how to print info printout and how to modify printer settings read user manual of ZEBRA printers.

40. ANNEX 04 - Barcode Scanner Configuration

1. For communication with barcode scanners, RADWAG scales use RS232 interfaces and simplex transmission (one-way direction), without handshaking. For this purpose, use of second line of the cable is sufficient. Used scanners should be equipped with RS232 interface, both hardware and software handshaking must be disabled.
2. Transmission parameters can be set for both weighing devices and scanners. For both devices the following parameters must comply: baud rate, data bits quantity, parity control, stop bits quantity; e.g. 9600,8,N,1 – baud rate 9600 bit/s, data 8-bits, no parity control, 1 stop bit.
3. Barcode scanners can send additional information apart from the expected barcode e.g. symbology (type of barcode). Due to the fact that RADWAG devices and software do not use such information, it is advisable to disable it.
4. Some RADWAG systems can omit unnecessary coded information by using parameters that mark the beginning and the length of the code subjected to analysis.
5. A special protocol is required in order the code be received by RADWAG equipment. It is required to program an appropriate prefix and suffix. In RADWAG-adopted standard, the prefix is 01 sign (byte) hexadecimal format, the suffix is 0D sign (byte) hexadecimal format.
6. Most barcode scanners allow to enable/disable different symbologies (barcode types).
7. Programming of scanners is performed by reading special barcodes.
8. Scanners marketed together with RADWAG systems are always configured according to the rules above.

Barcode with required prefix and suffix in hexadecimal format	Barcode without required -fixes in ASCII format	Code type
01 30 30 32 31 30 31 32 36 0D	00210126	EAN-8
01 30 31 32 33 34 35 36 37 38 39 0D	0123456789	CODE 2 OF 5
01 43 4F 44 45 20 33 39 20 54 45 53 54 0D	CODE 39 TEST	CODE 39
01 31 31 30 31 32 33 34 35 36 37 38 39 31 0D	1101234567891	EAN-13
01 43 6F 64 65 20 31 32 38 20 54 65 73 74 0D	CODE 128 Test	CODE 128



RADWAG BALANCES AND SCALES
ADVANCED WEIGHING TECHNOLOGIES

