

User manual

GT105K-12/Z CONTROL THERMOMETER

Manual number:
IMMU-50-01-12-13-PL



ELECTRONIC SCALES PRODUCER

RADWAG Wagi Elektroniczne, 26-600 Radom, Bracka 28, POLAND
Phone +48 48 38 48 800, fax. +48 48 385 00 10
Sales department: +48 (0-48) 366 80 06
export@radwag.com
www.radwag.com

DECEMBER 2013

Table of CONTENTS

1. BASIC INFORMATION	4
1.1. Intended use	4
1.2. Precautions	4
1.3. Warranty conditions.....	5
1.4. Information included in the user manual	5
2. UNPACKING	6
2.1. Unpacking	6
3. THE CONSTRUCTION	6
4. THE USE	7
4.1. Turning on and off	7
4.2. Temperature measurement	7
5. BATTERY REPLACEMENT	9
6. NOTES.....	10
7. ERRORS DESCRIPTION.....	10
8. TECHNICAL PARAMETRES.....	11

1. BASIC INFORMATION

1.1. Intended use

Thermometer is designed to be used for adjustment and control of the drying temperature in moisture analyzers of RADWAG company production.

Temperature is measured in [°C].

Thermometer enables temperature measurement thanks to a temperature sensor installed on a cable in a special holder. The holder simulates drying chamber shield of a moisture analyzer and that is why temperature measurement during temperature adjustment process and during temperature test process is carried out in conditions identical with those that occur during the samples drying process.

CAUTION:

Control thermometer is used for MAY type RADWAG moisture analyzers and for MAX and MAC moisture analyzers being in production from 6th June 2013.

1.2. Precautions

- A. Before the first use please read the User Manual thoroughly, use the device according to its intended purposes.
- B. Keep the thermometer set in its factory packaging in order to protect it from any incidental damages.
- C. The holder and the thermometer tip can be cleaned with a damp piece of cloth that was dipped in the alcohol substance. Be careful while cleaning the set so that not to cause any damage. Be especially careful while cleaning the measuring tip due to a delicate protective coating of the sensor. Damaged coating may lead to misleading readings. If the coating has been damaged it should be repaired by RADWAG company.
- D. The temperature sensor and the shield elements cannot be separated.
- E. No liquid or solid substances can be poured into the holder since it might cause damages.
- F. This set can be used only for its intended use, namely to adjust or control the temperature in a RADWAG moisture analyzers drying chamber.
- G. If no longer used the device and its packaging are to be utilized in accordance with the current law.

1.3. Warranty conditions

- A. RADWAG is obliged to repair or replace those parts that turn out to be faulty as far as production or construction matter is concerned,
- B. Defining faulties of unknown origin and setting the ways of their elimination can be done only in a presence of both, the producer and the user.
- C. RADWAG is not responsible for any damage or loss caused by other than authorized or proper, regular execution of both, production and servicing processes,
- D. The guarantee does not cover:
 - mechanical damages caused by other than regular operation as well as any thermic, chemic or other random event causes,
 - any set damages if the set had not been used in accordance with its intended use,
 - damages caused by media, liquids, water or being a result of a regular wear and tear,
 - maintenance (cleaning),
 - the battery replacement.
- E. The warranty becomes invalid when:
 - the repair is carried out in other service point than the authorized one,
 - the service states intrusion of unauthorized persons,
 - the device had not been used in accordance with its intended use.
- F. Detailed warranty conditions are to be found in the warranty card supplemented to the product.
- G. Authorized Service phone number is (0-48) 384 88 00 extension 106 and 107.

1.4. Information included in the user manual

The instruction must be read carefully even if the user is experienced in operating similar devices.

2. UNPACKING

2.1. Unpacking

Control thermometer set is placed in a factory packaging. One must unpack it and take the set out of the equipped with sponge cushions case.

It is indispensable to keep the set in the case when it is not used.

3. THE CONSTRUCTION

A special extra set with which the moisture analyzer is equipped with serves to calibrate the temperature.

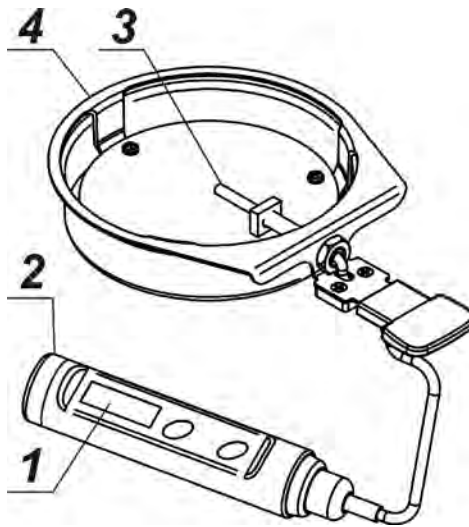

1. Thermometer head with the LCD display
2. The nut closing the battery compartment
3. Thermometer measuring tip
4. The thermometer holder together with the holder shield

The thermometer tip is made of OH18N9 stainless steel, it is blackened. The sensor is calibrated in the factory and the calibration parameters are stored in the integrated circuit of the device placed in the thermometer head. The stored parameters do not depend on the power supply.

The whole set can be calibrated on the clients request – to be treated as an extra order. In such a case a calibration certificate is awarded.

Measuring tip is connected to a thermometer head with the use of a silicone cable resistant to temperatures ranging from -60°C to 200°C. If the cable touches surface of lower or higher temperature its insulation can be damaged.

Functions:

Automatic turn-off system disables the battery from becoming flat.

„HOLD” function (keeps the readout on the screen).

Supplied with batteries 3x1.5V (Lr44).

CE marking.

4. THE USE

Thermometer assembling into the moisture analyzer and the usage (adjustment and the test) are described in the user manual of the moisture analyzer.

4.1. Turning on and off

After pressing the ON/OFF button the device turns on and the display shows all the symbols for a moment.



This is the display test. After about 2 seconds some of the symbols disappear and the device turns to the temperature measuring mode.

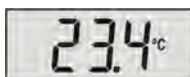

The device turns off automatically after 10 minutes of not being used (if no buttons have been pressed) or after pressing the ON/OFF button.

4.2. Temperature measurement

After the startup the thermometer measures the temperature in [°C]. Place the set in a drying chamber in order to execute the measurement (the description of such a procedure is to be found in the moisture analyzer user manual), turn the thermometer on, wait until the displayed value stabilizes and read the result. Remember that a sensor reaction time depends on a mass of the measuring element casing (the whole tip temperature has to stabilize).

How to assemble the set inside a drying chamber is to be read beneath, moisture analyzer of MAY series has been used as an example.

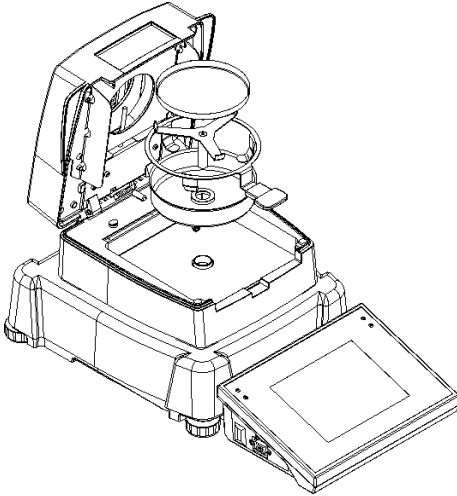

Step 1.

Take the following elements out of the drying chamber:

- disposable drying pan
- drying pan handle
- drying pan bracket
- chamber shield

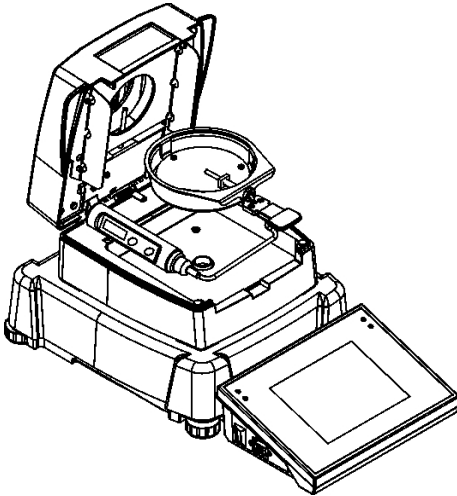

Step 2.

Place the set elements in a drying chamber:

- set shield
- and set holder together with the thermometer

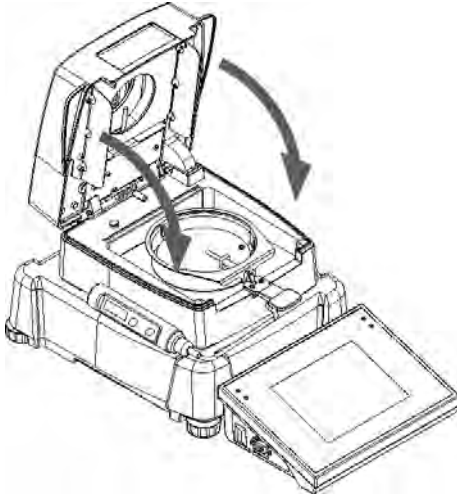

Step 3.

After the assembling process close the drying chamber and carry out the temperature calibration process.

CAUTION: All the steps must be carefully carried out so as not to cause any moisture analyzer mechanism damage. The temperature adjustment and control process depends of the moisture analyzer type and its description is to be found in particular user manuals.

5. BATTERY REPLACEMENT

<Lo> sign on the display showing up in turn with the measurement result informs about the need of the battery replacement. To do it the user must unscrew the nut of the thermometer head and take out 3 worn-out batteries by pulling up the ribbon. Next (s)he is to place new batteries inside (LR44 type, 1.5V voltage).

CAUTION:

While placing the batteries in the container pay attention to the positive and negative poles direction, it must accord with the marks in the container. The same poles of all the three batteries must face the same direction. The negative pole is placed on the flat spring side, the positive pole is placed on the spiral spring side.

Putting the batteries into the container the other way round may lead to the damage of the device.

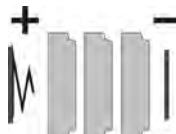

The easiest way is to slip the batteries one after another from the flat spring side and next push them into the spiral spring direction. Finally the user should screw the nut tight.

New batteries life is about 7 month long.

If the device is not in use for a longer period of time the batteries should be taken out of the device. If not it may happen that they will spill and damage the device.

Taking the batteries out does not result in the calibration data loss.

6. NOTES

The thermometer is a water-proof device, it has been tested before being put up for sale. Its leakproofness is assured due to three sealing rings. Their placement is presented in the picture beneath.

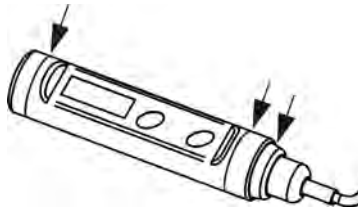

Two of the rings are to be found on each side of the casing, the third one is placed inside the nut holding the head with the electrodes. While replacing the batteries it is recommended to grease the ring with the silicone in order not to be constrained to screw the nut with too great force. Before the screwing it needs to be checked whether the ring is in the correct place, next the nut must be screwed. If it is left loose, the inside of the device may leak and spoil the device. Damage of this kind is not covered by the warranty. The thermometer head cannot be heated with a temperature higher than 70°C due to the material its casing has been made of. The casing is sensitive to dissolvent.

7. ERRORS DESCRIPTION

HLP	Factory calibration loss, contact RADWAG company.
Lo	Low battery charge state, showing in turn with the measurement result. Batteries must be replaced (description is to be found above).

8. TECHNICAL PARAMETRES

Measuring range	-70 ÷ 400 °C		
Resolution	range -70 ÷ 199.9 °C — 0.1 °C , over 199.9°C — 1.0 °C		
The device accuracy	±0.2 °C ±1.0 °C	for for	-70 ÷ 199.9 °C 199.9 ÷ 400 °C
Measurement accuracy depending on the class of sensor accuracy	±0.9 °C ±1.0 °C ±1.5 °C ±3.0 °C	for for for for	-70 ÷ 0 °C 0 ÷ 100 °C 100 ÷ 200 °C 200 ÷ 400 °C
Mass of the set	199 g		
Size of the thermometer head	l = 120 mm, ø = 26 mm		
Head – thermometer cable length	~900 mm		
Max length of the continuous operation time	~80 hours		
Power	batteries 3x1,5V LR44		

MANUFACTURER
OF ELECTRONIC WEIGHING INSTRUMENTS



RADWAG WAGI ELEKTRONICZNE
26 – 600 Radom, ul. Bracka 28

Phone: +48 48 38 48 800, fax. + 48 48 385 00 10

Sales department: + 48 48 366 80 06

e-mail: export@radwag.com

www.radwag.pl